

Schöck Bauteile GmbH

Vimbucher Strasse 2
D-76534 Baden-Baden
Germany

Tel: 00 49 72 23 967-0 Fax: 00 49 72 23 967-450
e-mail: schoeck@schoeck.de
website: www.schoeck.de



Agrément Certificate
10/4801
Product Sheet 1

SCHÖCK ISOKORB RANGE OF THERMAL INSULATION COMPONENTS

SCHÖCK ISOKORB CONNECTORS — TYPE KST MODULES

PRODUCT SCOPE AND SUMMARY OF CERTIFICATE

This Certificate relates to Schöck Isokorb Connectors — Type KST Modules, for connecting steel to steel or to concrete structures, where it is necessary to reduce heat transfer.

AGRÉMENT CERTIFICATION INCLUDES:

- factors relating to compliance with Building Regulations where applicable
- factors relating to additional non-regulatory information where applicable
- independently verified technical specification
- assessment criteria and technical investigations
- design considerations
- installation guidance
- regular surveillance of production
- formal three-yearly review.

KEY FACTORS ASSESSED

Mechanical resistance and stability — the modules have been designed to transfer the loads from steel beams to the steel or concrete structure (see section 5).

Behaviour in relation to fire — the modules will require the same fire resistance as the main structure (see section 6).

Hygrothermal performance — the modules can contribute to limiting surface condensation risk and excessive additional heat loss (see section 7).

Durability — the modules are made from stainless steel giving adequate protection against corrosion (see section 9).

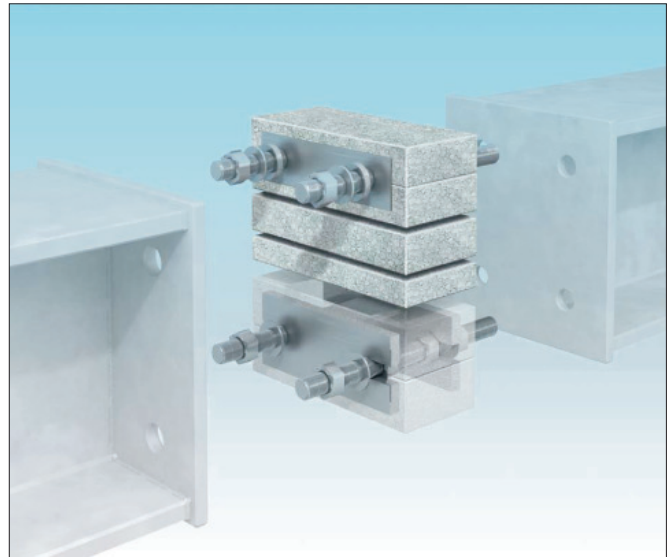

The BBA has awarded this Agrément Certificate to the company named above for the products described herein. These products have been assessed by the BBA as being fit for their intended use provided they are installed, used and maintained as set out in this Certificate.

On behalf of the British Board of Agrément

Date of First issue: 9 December 2010

Brian Chamberlain
Head of Approvals — Engineering

Greg Cooper
Chief Executive

The BBA is a UKAS accredited certification body — Number 113. The schedule of the current scope of accreditation for product certification is available in pdf format via the UKAS link on the BBA website at www.bbacerts.co.uk

Readers are advised to check the validity and latest issue number of this Agrément Certificate by either referring to the BBA website or contacting the BBA direct.

British Board of Agrément
Bucknalls Lane
Garston, Watford
Herts WD25 9BA

tel: 01923 665300
fax: 01923 665301
e-mail: mail@bba.star.co.uk
website: www.bbacerts.co.uk

©2010

Regulations

In the opinion of the BBA, Schöck Isokorb Connectors – Type KST Modules, if used in accordance with the provisions of this Certificate, will meet or contribute to meeting the relevant requirements of the following Building Regulations:



The Building Regulations 2010 (England and Wales)

Requirement: A1	Loading
Comment:	The products have sufficient strength and stiffness to sustain and transmit the design loads in accordance with sections 5.1 to 5.6 of this Certificate.
Requirement: B3(1)	Internal fire spread (structure)
Comment:	A construction incorporating the products and the manufacturer's fire-protection details will provide suitable fire resistance. See section 6.1 of this Certificate.
Requirement: C2 (c)	Resistance to moisture
Comment:	The products can contribute to minimising the risk of surface condensation. See sections 7.1 and 7.3 of this Certificate.
Requirement: L1(a)(i)	Conservation of fuel and power
Comment:	The products can contribute to meeting this Requirement. See sections 7.1 and 7.3 and the <i>Installation</i> part of this Certificate.
Requirement: Regulation 7	Materials and workmanship
Comment:	The products are acceptable. See section 9.1 of this Certificate.



The Building (Scotland) Regulations 2004 (as amended)

Regulation: 8(1)(2)	Fitness and durability of materials and workmanship
Comment:	The products comply with the requirements of this Regulation. See sections 5.1 to 5.6 and 9.1 and the <i>Installation</i> part of this Certificate.
Regulation: 9	Building standards – construction
Standard: 1.1(a)(b)	Structure
Comment:	A structure incorporating the products has sufficient strength and stiffness to sustain and transmit the design loads in accordance with sections 5.1 to 5.6 of this Certificate, with reference to clauses 1.1.1 ⁽¹⁾⁽²⁾ , 1.1.2 ⁽¹⁾⁽²⁾ , 1.1.3 ⁽¹⁾⁽²⁾ and 1.1.5 ⁽¹⁾⁽²⁾ of this Standard.
Standard: 2.3	Structural protection
Comment:	A construction incorporating the products and the manufacturer's fire-protection details will provide suitable fire resistance, with reference to clauses 2.3.0 ⁽¹⁾⁽²⁾ , 2.3.1 ⁽¹⁾⁽²⁾ and 2.3.3 ⁽¹⁾⁽²⁾ of this Standard. See section 6.1 of this Certificate.
Standard: 3.15	Resistance to moisture
Comment:	The products can contribute to minimising the risk of surface condensation, with reference to clauses 3.15.0 ⁽¹⁾⁽²⁾ , 3.15.1 ⁽¹⁾⁽²⁾ and 3.15.4 ⁽¹⁾⁽²⁾ of this Standard. See sections 7.1 and 7.3 of this Certificate.
Standard: 6.1(b)	Carbon dioxide emissions
Comment:	The products, when used in conjunction with additional insulation, can contribute to satisfying this Standard, with reference to clauses 6.1.1 ⁽¹⁾ , 6.1.2 ⁽²⁾ and 6.1.6 ⁽¹⁾ of this Standard. See sections 7.1 and 7.3 of this Certificate.
Standard: 6.2	Building insulation envelope
Comment:	The products can contribute to satisfying this Standard, with reference to clauses 6.2.3 ⁽¹⁾ , 6.2.5 ⁽²⁾ , 6.2.10 ⁽¹⁾ and 6.2.12 ⁽²⁾ of this Standard. See sections 7.1 and 7.3 of this Certificate. (1) Technical Handbook (Domestic). (2) Technical Handbook (Non-Domestic).



The Building Regulations (Northern Ireland) 2000 (as amended)

Regulation: B2	Fitness of materials and workmanship
Comment:	The products are acceptable. See section 9.1 and the <i>Installation</i> part of this Certificate.
Regulation: D1	Stability
Comment:	The products have sufficient strength and stiffness to sustain and transmit the design loads in accordance with sections 5.1 to 5.6 of this Certificate.
Regulation: E4(1)	Internal fire spread structure
Comment:	A construction incorporating the products and the manufacturer's fire-protection details will provide suitable fire resistance. See section 6.1 of this Certificate.
Regulation: F2(a)(i)	Conservation measures
Comment:	The products can contribute to satisfying this Regulation. See sections 7.1 and 7.3 of this Certificate.
Regulation: F3	Target carbon dioxide Emission Rate
Comment:	The products, when used in conjunction with additional insulation, can contribute to satisfying this Regulation. See section 7.4 of this Certificate.

In the opinion of the BBA, the use of Schöck Isokorb Connectors — Type KST Modules, in relation to this Certificate, is not subject to the requirements of these Standards.

Non-regulatory Information

NHBC Standards 2010

NHBC accepts the use of Schöck Isokorb Connectors — Type KST Modules, when installed and used in accordance with this Certificate, in relation to *NHBC Standards, Part 6 Superstructure (excluding roofs)*, Chapter 6.5 *Steelwork (D2 Structural design)*.

Technical Specification

1 Description

1.1 Type KST connectors are made up of a combination of ZST, QST and ZQST modules with insulating adaptors used to control the centres of the bolt assemblies. A typical connector is shown in Figure 1.

Figure 1 A typical Type KST connector



1.2 The modules (see Figure 2) comprise:

- KST-ZST — two rectangular stainless steel plates (40 mm by 150 mm by 2 mm thick) holding two 16 mm or 22 mm diameter stainless steel bolt assemblies (at 100 mm horizontal centres) held apart by insulation 80 mm deep. With 16 mm bolts, the module is coded KST-ZST 16 and with 22 mm bolts KST-ZST 22. The outer washers on the bolt assemblies take the form of a ball and socket and conical disc
- KST-QST — as KST-ZST but with a stainless steel SHS (50 mm square box section, 56 mm deep) welded between plates of heavier section (60 mm by 150 mm by 12 mm thick), and plain washers on the bolt assemblies. Depending on bolt diameter, coded as KST-QST 16 and KST-QST 22
- KST-ZQST — combines the plate and box section features of the KST-QST module with the bolt assemblies of the KST-ZST module. Depending on bolt diameter, coded as KST-ZQST 16 and KST-ZQST 22.

Figure 2 Range of modules

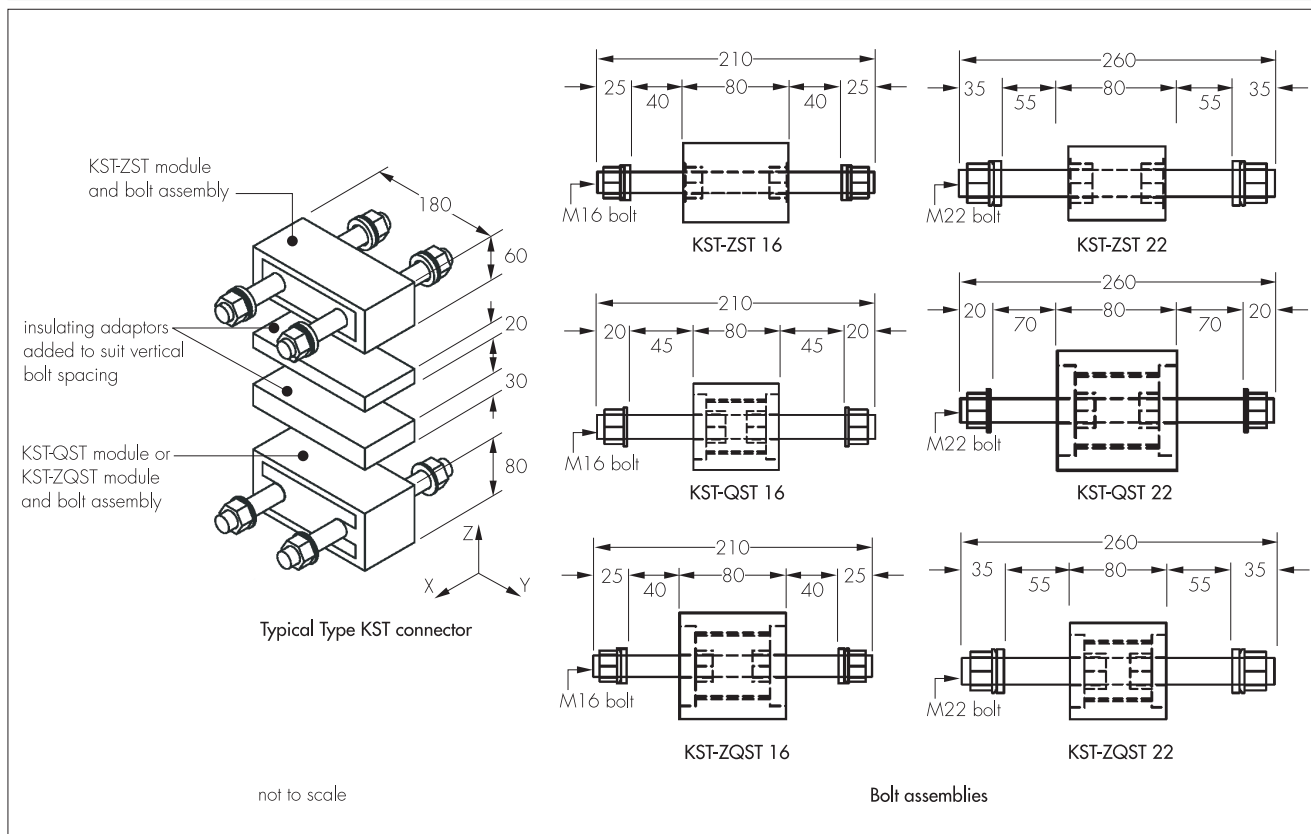

1.3 With these KST modules, it is possible to achieve a vertical bolt separation of up to 120 mm. Greater distance between the modules can be achieved by inserting further insulating adaptors or corresponding insulating block.

1.4 Insulating adaptors are available in two thicknesses (30 mm and 20 mm) and are of high-density polystyrene ($\lambda = 0.031 \text{ W}\cdot\text{m}^{-1}\cdot\text{K}^{-1}$).

1.5 The steel components are fabricated from stainless steel in accordance with BS EN 10088-4 : 2009, grade 1.4401, 1.4404 or 1.4571 (Mo-Cr-Ni austenitic).

2 Delivery and site handling

2.1 Products are normally supplied in packages containing installation instructions. During handling, care must be taken to avoid bending bolts or damaging the polystyrene.

2.2 To help with identification, the modules are protected by colour-coded packaging:

- KST-ZST yellow
- KST-QST light blue
- KST-ZQST royal blue.

2.3 Packages must be stored undercover and away from direct sunlight or contact with solvents or other harmful chemicals.

Assessment and Technical Investigations

The following is a summary of the assessment and technical investigations carried out on Schöck Isokorb Connectors — Type KST Modules.

Design Considerations

3 General

3.1 Schöck Isokorb Connectors — Type KST Modules are used in steel and reinforced concrete structures, allow full transfer of the load from an external steel beam into the main structure and cater for connecting:

- free cantilever steel beams to a steel structure
- steel beams to a steel structure
- between reinforced concrete and steel structures.

3.2 When designed and installed in accordance with the Certificate holder's instructions, the connectors have the capability of transferring tensile, shear and compressive forces through to the supporting structure. The connectors are made by selecting the appropriate modules according to the forces involved:

- KST-ZST — absorbs tensile forces. In combination with the KST-QST module can absorb some compressive forces
- KST-QST — absorbs compressive forces and shear forces via the box section. The interaction condition given in section 5.3 must be satisfied
- KST-ZQST — used where tensile forces are continuously transmitted and horizontal forces due to temperature deformation are transferred from the structure into the connection.

3.3 The product should be positioned to align with the insulation in the main building elements.

3.4 When used in environments with a high chlorine content (eg in indoor swimming pools) an appropriate Schöck-protection⁽¹⁾ must be used.

(1) Not covered by the scope of this Certificate but details are available from the Certificate holder.

4 Practicability of installation

4.1 The modules can be installed by operatives familiar with the erection and bolting of structural steel sections. The operatives will need to be competent and appropriately trained and take account of the instructions provided with each KST module.

4.2 It is important for designers, planners, contractors and/or installers to ensure that the installation is in accordance with the Certificate holder's instructions and the information given in this Certificate.

5 Mechanical resistance and stability

5.1 The ultimate tensile strength of stainless steel bolts is in accordance with BS EN ISO 3506-1 : 2009 and can be taken as 700 N·mm⁻². The ultimate tensile strength of the rectangular hollow section and 12 mm thick pressure plate (QST module) with enhanced mechanical properties, is in accordance with BS EN 10088-4 : 2009 and can be taken as 600 N·mm⁻² and 550 N·mm⁻² respectively.

5.2 The applied design forces (tensile, compression and/or shear) on the modules must be calculated by a structural engineer in accordance with BS 5950-1 : 2000 or BS EN 1993-1-4 : 2006 and SCI Publication P291 *Structural Design of Stainless Steel* to resist the applied loads and/or other direct loads⁽¹⁾.

(1) Design data can be obtained from the Certificate holder.

5.3 Calculations should be carried out to ensure that the applied design forces on the modules do not exceed the working loads. For guidance, loads in accordance with BS 5950-1 : 2000 are given in Table 1. The Certificate holder's advice should be sought in this respect.

Table 1 Working loads to BS 5950-1 : 2000⁽¹⁾

Load parameter (unit)	Module					
	KST 16	KST 22	KST-QST 16 KST-ZQST 16	KST-QST 22 KST-ZQST 22	KST-ZST 16	KST-ZST 22
Out-of-plane shear force $H_{y,Rd}$ (kN)	$\pm 6^{(2)}$	$\pm 6^{(2)}$	$\pm 6^{(2)(3)}$	$\pm 6^{(2)(3)}$	0	0
In-plane shear force $V_{z,Rd}$ (kN)	30	36	30 ⁽³⁾	36 ⁽³⁾	0	0
Axial tension load $F_{x,t,Rd}$ (kN)	116.8 ⁽⁴⁾	225.4 ⁽⁴⁾	116.8 ⁽³⁾	225.4 ⁽³⁾	116.8	225.4
Axial compression load $F_{x,c,Rd}$ (kN)	116.8 ⁽⁴⁾	225.4 ⁽⁴⁾	116.8 ⁽³⁾	225.4 ⁽³⁾	0	0
In-plane moment $M_{y,Rd}$ (kN·m)	$\alpha x F_{x,t,Rd}^{(5)}$	$\alpha x F_{x,t,Rd}^{(5)}$	0 ⁽⁶⁾	0 ⁽⁶⁾	0	0
Out-of-plane moment $M_{z,Rd}$ (kN·m)	⁽²⁾⁽⁷⁾	⁽²⁾⁽⁷⁾	⁽²⁾⁽⁷⁾	⁽²⁾⁽⁷⁾	0	0

(1) A material partial factor of 1.2 has been applied to calculate the design values of the component.

(2) The Certificate holder's Technical Information *Schöck Isokorb type KST* should be consulted, especially in respect of expansion joints/fatigue resistance (available by downloading from the Certificate holder's website).

(3) The interaction condition $3 V_z + 2 H_y + F_{x,t} = \max F_{x,t,d} \leq F_{x,t,Rd}$ needs to be taken into account in the event of simultaneous tensile force and shear force loads.

(4) If the KST-ZST module is subjected to pressure loads within a KST connection, it can absorb a maximum of $1/3 F_{x,t,Rd}$ as a compressive force. In this case, the interaction condition (footnote 3) must be noted.

(5) α = distance between the tension rods and compression bars of the Isokorb element (KST connection — inner lever arm); minimum possible axis separation between tension rods and compression bars = 50 mm (without insulating adapters after processing of the polystyrene).

(6) When using at least two modules arranged one above the other, it is possible to transfer both positive and negative forces (moments and shear forces), in accordance with the Certificate holder's Technical Information.

(7) Further information and recommendations can be obtained from the Certificate holder.

5.4 The vertical separation between bolts (tension and compression rods) must not be less than 50 mm.

5.5 The modules are intended for use with primary static loads.

5.6 With steel members up to 6 m in length, the modules are designed to accommodate changes in length caused by the temperature deformation. For steel members longer than 6 m, an expansion joint is required as shown in Figure 3.

Figure 3 Position of expansion joints

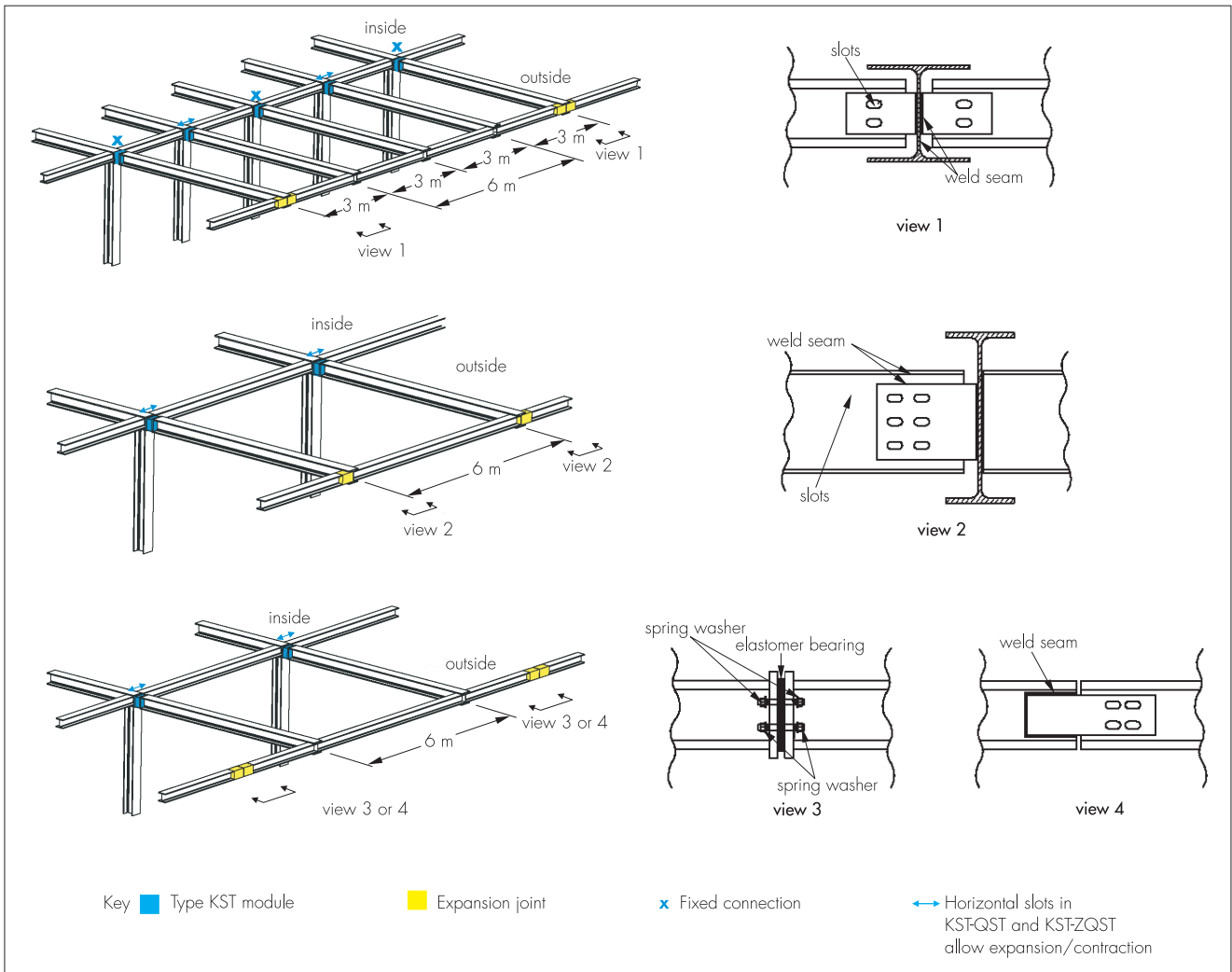

6 Safety in case of fire



6.1 Fire safety measures for modules should be equivalent to those of the steel structure. Fire resistance can be achieved by using a board lining (see Table 2 and Figure 4); other fire protection lining should be tested in accordance with BS 476-21 : 1987.

Table 2 Fire resistance with board lining⁽¹⁾ (as shown in Figure 4)

Fire resistance (minute)	Lining thickness (mm)
30	10
60	15
90	20
120	25

(1) Tests carried out using Promatect-H calcium silicate boards (outside the scope of this Certificate).

Figure 4 Typical detail of lined connection

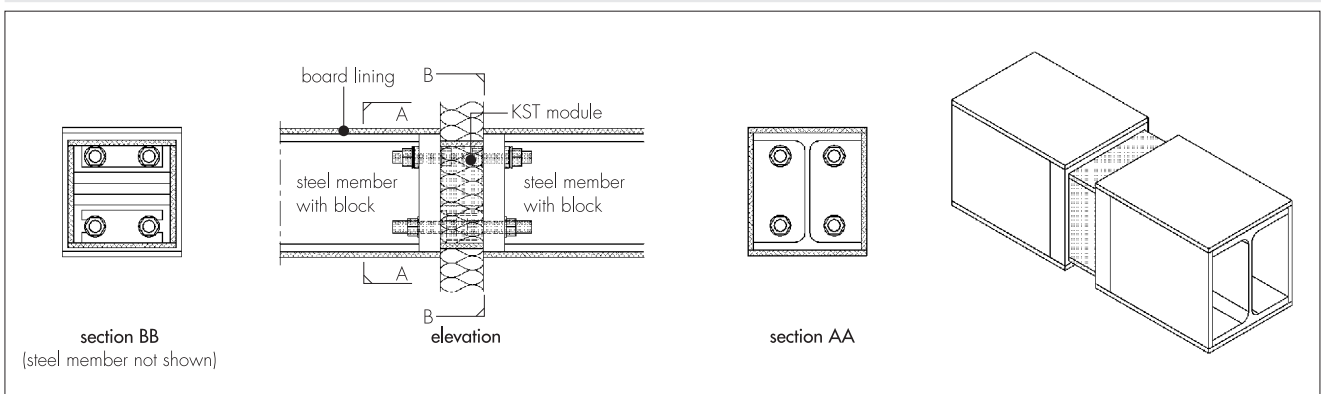

6.2 For other board lining when used in a structure subject to fire resistance requirements, an appropriate assessment or test relating to that structure must be carried out by a United Kingdom Accreditation Service (UKAS) laboratory accredited for the test concerned.

7 Hygrothermal performance



7.1 Indicative computer modelling of a single module/beam connection with its insulation layer coinciding with an 80 mm thick layer of wall insulation ($\lambda = 0.035 \text{ W}\cdot\text{m}^{-1}\cdot\text{K}^{-1}$), and not including other construction details, indicates that temperature factors in excess of 0.75 can be achieved.

7.2 The heat loss rate (effective psi value) and minimum surface temperature factor (f_{Rsi}) of external envelope junctions incorporating the products will depend on the number of modules in the junction and the overall construction and should be modelled in accordance with BRE Report 497 *Conventions for calculating linear thermal transmittance and temperature factors*.



7.3 Junctions that achieve the appropriate critical surface temperature factors given in BRE Information Paper IP1/06 *Assessing the effects of thermal bridging at junctions and around openings*, Table 3, will adequately limit excessive additional heat loss and risk of surface condensation.



7.4 For the purposes of carbon emission calculations, junctions incorporating the products should include additional insulation or the heat loss be compensated for by improved building fabric or services performance.

7.5 It is essential that the insulation component of the modules coincides with the plane of the wall insulation layer, without gaps or bridging.

8 Maintenance

Once installed correctly, maintenance is not required.

9 Durability



9.1 Connections will have a service life of not less than 60 years.

9.2 As the KST modules are made up of austenitic stainless steel compliant with steel designation numbers 1.4401, 1.4404 and 1.4571 as described in BS EN 10088-1 : 2005, the components have a typical corrosion resistance.

9.3 With galvanized or painted steel front plates, the area of galvanized steel is greater than that of the stainless steel, therefore, there is minimal risk of bimetallic corrosion.

Installation

10 General

Installation instructions are supplied with each module. The operatives will need to be competent and appropriately trained and take account of the instructions provided.

11 Procedure

11.1 The correct type of module is selected in accordance with the design, and the top and bottom parts fixed to one steel member.

11.2 The module is seated in position on the other steel member and the top and bottom bolt alignment checked after placing the polystyrene spacer adaptor in position between the end plates.

11.3 A final position check is made prior to the designed torque being applied to the top and bottom nuts.

Technical Investigations

12 Tests

The manufacturing process was examined, including the methods adopted for quality control, and details were obtained of the quality and composition of the materials used.

13 Investigations

13.1 An assessment was made of test data relating to:

- compressive strength
- tensile strength
- deflection.

13.2 An assessment was made of the design calculation in accordance with BS 5950 : 2000 and SCI publication P291 *Structural Design of Stainless Steel* relating to:

- material properties
- capacity of tension modules
- capacity of compression modules
- capacity of threaded bolts.

13.3 An assessment of thermal performance was carried out by the Oxford Institute for Sustainable Development and results are given in their report 060814SCH.

Bibliography

BS 476-21 : 1987 *Fire tests on building materials and structures — Methods for determination of the fire resistance of loadbearing elements of construction*

BS 5250 : 2002 *Code of practice for control of condensation in buildings*

BS 5950-1 : 2000 *Structural use of steelwork in building — Code of practice for design — Rolled and welded sections*

BS EN 1993-1-4 : 2006 *Eurocode 3 — Design of steel structures — General rules — Supplementary rules for stainless steels*

BS EN 10088-1 : 2005 *Stainless steels — List of stainless steels*

BS EN 10088-4 : 2009 *Stainless steels — Technical delivery conditions for sheet/plate and strip of corrosion resisting steels for construction purposes*

BS EN ISO 3506-1 : 2009 *Mechanical properties of corrosion-resistant stainless steel fasteners — Bolts, screws and studs*

Conditions of Certification

14 Conditions

14.1 This Certificate:

- relates only to the product/system that is named and described on the front page
- is granted only to the company, firm or person named on the front page — no other company, firm or person may hold or claim any entitlement to this Certificate
- is valid only within the UK
- has to be read, considered and used as a whole document — it may be misleading and will be incomplete to be selective
- is copyright of the BBA
- is subject to English law.

14.2 Publications and documents referred to in this Certificate are those that the BBA deems to be relevant at the date of issue or re-issue of this Certificate and include any: Act of Parliament; Statutory Instrument; Directive; Regulation; British, European or International Standard; Code of Practice; manufacturers' instructions; or any other publication or document similar or related to the aforementioned.

14.3 This Certificate will remain valid for an unlimited period provided that the product/system and the manufacture and/or fabrication including all related and relevant processes thereof:

- are maintained at or above the levels which have been assessed and found to be satisfactory by the BBA
- continue to be checked as and when deemed appropriate by the BBA under arrangements that it will determine
- are reviewed by the BBA as and when it considers appropriate.

14.4 In granting this Certificate, the BBA is not responsible for:

- the presence or absence of any patent, intellectual property or similar rights subsisting in the product/system or any other product/system
- the right of the Certificate holder to manufacture, supply, install, maintain or market the product/system
- individual installations of the product/system, including the nature, design, methods and workmanship of or related to the installation
- the actual works in which the product/system is installed, used and maintained, including the nature, design, methods and workmanship of such works.

14.5 Any information relating to the manufacture, supply, installation, use and maintenance of this product/system which is contained or referred to in this Certificate is the minimum required to be met when the product/system is manufactured, supplied, installed, used and maintained. It does not purport in any way to restate the requirements of the Health & Safety at Work etc Act 1974, or of any other statutory, common law or other duty which may exist at the date of this Certificate; nor is conformity with such information to be taken as satisfying the requirements of the 1974 Act or of any statutory, common law or other duty of care. In granting this Certificate, the BBA does not accept responsibility to any person or body for any loss or damage, including personal injury, arising as a direct or indirect result of the manufacture, supply, installation, use and maintenance of this product/system.