



Flexible Space

Under Floor Air Conditioning

CAM-C Direct Expansion PRODUCT DESCRIPTION

ISSUE 3.0
FEBRUARY 2017



AET Manufacturing (UK) Ltd. Registered in England. Company No. 10050347

© 2017 All rights reserved.

AET Manufacturing (UK) Ltd. reserves the right to make improvements to the products described in this manual at any time without notice.

No part of this manual may be reproduced, copied, translated or transmitted, in any form, or by any means without the prior written permission of AET Manufacturing (UK) Ltd.

Information provided in this manual is intended to be accurate and reliable. However, AET Manufacturing (UK) Ltd. assumes no responsibility for its use; nor for any infringement of rights of third parties which may result from its use.

Table of Contents

Section One: Product Description	2
1.0 General	2
1.1 Cabinet	3
1.2 Filter Section	3
1.3 Heat Exchanger Coils	4
1.4 Fan Section	5
1.5 Electric Board	5
1.6 Control System	6
1.7 Humidifier	6
1.8 Baseframe	7
1.9 Optional Modules	7
1.10 Packing	7
1.11 Product Quality and Safety	7
1.12 Refrigerant Circuit	8
 Section Two: Technical Data	 9
2.0 Overall Dimensions and Unit Weights	9
2.1 Opening in the Raised Floor and Service Area	11
2.2 Baseframe Configuration	12
2.3 Noise Data	14
2.4 Electrical Data	15
2.5 Pipe Connections	16
2.6 Instrument Installation	18

Section One: Product Description

1.0 General

The Conditioned Air Module or CAM-C Direct Expansion (DX) filters and conditions the air distributed in the underfloor plenum for an office zone. It consists of the following main sections:

- Cabinet
- Filter section
- Heat exchanger coils
- Fan section
- Electric board
- Control system
- Humidifier (optional)
- Baseframe



The air returning from the rooms enters the CAM-C (DX) from the underfloor void. It is then filtered and conditioned according to the temperature and humidity set-points selected on the electronic control panel. The conditioned air is then delivered to the underfloor plenum through a suitable baseframe for discharge to the space by Terminal Units (TUx).

The CAM-C (DX) is available as standard in three sizes: CAM-C15, CAM-C25 and CAM-C35. Custom built units can be considered. Nominal cooling capacities vary from 7 to 35 kW, and heating capacities from 7.5 to 50 kW. A single unit can cover the air conditioning needs of areas up to 300 m². Beyond 300m² consideration should be given to zone orientation and temperature control to ensure optimum design.

The CAM-C (DX) is particularly suitable for both cellular and open plan offices and has been designed to be enclosed in partitions or purpose made cupboards. Although the CAM-C (DX) zone unit may be located within an enclosure, because it is quiet in operation, it can be located free-standing in the open space. The zone units can be located in a variety of locations such as corridors, technical rooms or in normal working spaces. Installation is fast and easy because no duct connections are required.

Fresh air can be discharged directly into the return air section of the under floor plenum for treatment by the CAM-C (DX) or ducted directly to the unit when appropriate.

1.1 Cabinet

The cabinet consists of a robust frame made of welded 2mm sheet steel with front and side panels internally lined with 23mm thick thermal and acoustic insulation in self-extinguishing polyurethane foam (type HELIOCELL – 30/AU). The internal discharge plenum is lined with the same material.

The front panels ensure easy access to the electric board and the electronic control; for safety reasons, a special key lock prevents unauthorised access. When required, additional front and side panels can be supplied, increasing the acoustic insulation. The frame and panels are finished with an epoxy polyester powder coat of pearl grey colour (Ral 7035).

1.2 Filter Section

The filters in the front section of the unit provide continuous high efficiency filtration of the re-circulated air. This achieves the required degree of clean air in the office area. Disposable filters are made of deep pleated fabric, mounted in galvanised frames for easy replacement.

Filters with G3 efficiency, are fitted as standard, G4, F5, F7 or carbon filters may be fitted as alternative options.

The filter section provides easy access to facilitate the inspection and replacement of filters. A clogged filter switch can be fitted on request and linked to the on-board control panel for indication/alarm purposes.

Each CAM includes a number of disposable low velocity synthetic fibre filters:

- CAM-C (DX) 15: 2 filters (1000 x 410 x 88 mm)
- CAM-C (DX) 25: 3 filters (1000 x 410 x 88 mm)
- CAM-C (DX) 35: 4 filters (1000 x 445 x 88 mm)

1.3 Heat Exchanger Coils

General

The CAM-C direct expansion (DX) is available in two operation configurations:

1. Cooling and Heating

One (1) direct expansion coil for cooling and heating (connected to heat pump) is the standard configuration.

2. Cooling only

If heating is not required the unit can be set to cooling only.

In the event that humidity control is required; both cooling and heating coils will provide dehumidification and reheating functions.

Each direct expansion (DX) coil is connected to an expansion valve located in the external condensing unit.

- **CAM-C (DX) 15:** the standard direct expansion (DX) coil has three rows, copper tubes with 10 aluminium plates per inch, with a face area of 0.8 m² to optimise the speed of air flow through the corrugated fins.

Optional/reheat aluminium electric heaters: 4.5 kW total capacity, with two steps automatic intervention (1.5 +3.0 kW)

- **CAM-C (DX) 25:** the standard direct expansion (DX) coil has three rows, copper tubes with 10 aluminium plate fins per inch, with a face area of 1.21 m² to optimise the speed of air flow through the corrugated fins.

Optional/reheat Aluminium electric heaters: 10.35 kW total capacity with three steps automatic intervention (3.45 + 6.90 kW) or 4.5 kW total capacity with two steps automatic intervention (1.5 + 3.0 kW)

- **CAM-C (DX) 35:** the standard direct expansion (DX) coil has three rows, copper tubes with 10 aluminium plate fins per inch, with a face area of 1.76 m² to optimise the speed of air flow through the corrugated fins.

Optional/reheat Aluminium electric heaters: 14.85 kW total capacity with three steps automatic intervention (4.95 + 9.90 kW) or 10.35 kW total capacity with three steps automatic intervention (3.45 + 6.90 kW).

1.4 Fan Section

The CAM-C (DX) is equipped with quiet, low speed centrifugal fans, each with integral variable speed independent electric motor with built-in thermal protection. Fan speeds can be selected using the Flexmatic display which allows different voltage outputs to AC fan speed controller or inbuilt EC fan motor control. The fans are double inlet with statically and dynamically balanced impellers with lifetime lubricated bearings for quiet, vibration-free operation. They are available in AC or EC options, IP10 (AC motors) and IP20 (EC Motors) electric protection is standard. The fan section is downstream of the cooling coil, to provide uniform air distribution across the coil with low pressure drop and low noise. The CAM-C (DX) is provided with an electronic flow sensor to check the operation of the unit. The fans are mounted on anti-vibration frames and secured by toggle belts for easy removal.

1.5 Electric Board

The units are designed for 400 (+/- 10%) V/3ph+N+PE/50Hz for versions including electric heating and/or humidification and 230V (+/- 10%) V/1ph+N+PE/50 Hz for other versions. The electric board is factory wired and complies with IEC standards. It is completely isolated from the air stream and accessible from the front panel, and protected by safety locks with a special key. Components include: main isolator, transformer, circuit breakers, fan motor, humidifier,

electric heater contactors and fresh air module (FA5/7) contacts. Free contacts for remote signalling are available.

1.6 Control System

A factory-wired electronic control system provides an automatic and continuous control of the supply air temperature and humidity to maintain the area at the required conditions. Normally the CAM-C (DX) unit operates at a selected constant speed which can be adjusted on the Flexmatic display. Alternatively The Flexface controller plus Flexmatic display can automatically control the airflow supplied by the CAM-C (DX) on the basis of the air volume drawn by the TUx (connected to the CAM-C (DX)) by Flexbus data cable (Variable Volume).

Additional modules can be fitted for humidity control, outdoor compensation and connection to an external Building Management System (BMS). Electronic automatic control comprises:

- 1 x Flexface controller
- 1 x Flexmatic display (optional)
- 1 x zone room air temperature sensor
- 1 x supply air temperature sensor
- 1 x electrical heater card (where required)
- 1 x Humidifier control
- 1 x Water detector (Liquistat)

In addition to the main internal control panel, an On/Off switch and an optional override switch are located externally on the front face of the unit. The unit run time may be extended by pressing and holding the override push button if installed. The length of “run on” time may be selected on the Flexmatic display.

The outdoor units are supplied with power separately and take a START-STOP signal from the CAM. Refer to the relevant product manual for further information.

1.7 Humidifier

An electric steam humidifier is available as an option (5 kg/hr nominal steam humidifier with electronic control and humitemp sensor). The humidifier can use any type of hard or soft water, provided it is not distilled water. It produces clean, virtually particle-free and bacteria free steam instantaneously from a disposable plastic cylinder fitted with an electric heating

element. A warning light shows when the cylinder must be replaced. An automatic flush control system is standard, and limits the salt concentration in the cylinder.

1.8 Baseframe

The baseframe can be of any height to match the adjacent raised access floor. There are two models of baseframe: TP (triangular plate) and RP (rectangular plate). Using TP and RP baseframes, six different baseframe configurations are available to adapt the CAM-C (DX) installation to any zone layout requirement. Air delivery and intake can be from the front, side or back of the unit according to the baseframe configuration. Return air can be from sides or from the front of the unit beneath the access floor. The baseframe is made of welded steel sheet and painted the same colour as the CAM-C (DX). The baseframe has adjustable height supports with anti-vibration pads fitted to obtain the correct height and to compensate for slab irregularities. See section 2.2 for further information on baseframe configuration.

1.9 Optional Modules

These optional modules are available:

- Humidification (described above)
- Dehumidification only
- Setpoint compensation with the external temperature electronic compensator and outdoor air temperature sensor
- Connection to BMS via Flexgateway. (local or remote control) Modbus and Bacnet options.

1.10 Packing

The CAM-C (DX) is protected and wrapped with extensible film for transportation. Wooden crates or cases and hermetic bags can be supplied for sea transport on request.

1.11 Product Quality and Safety

The units of the CAM-C (DX) series are marked as compliant with the European directives concerning mechanical, electrical and electromagnetic safety (98/37/CE, 89/336/CEE, 73/23/CEE).

1.12 Refrigerant Circuit

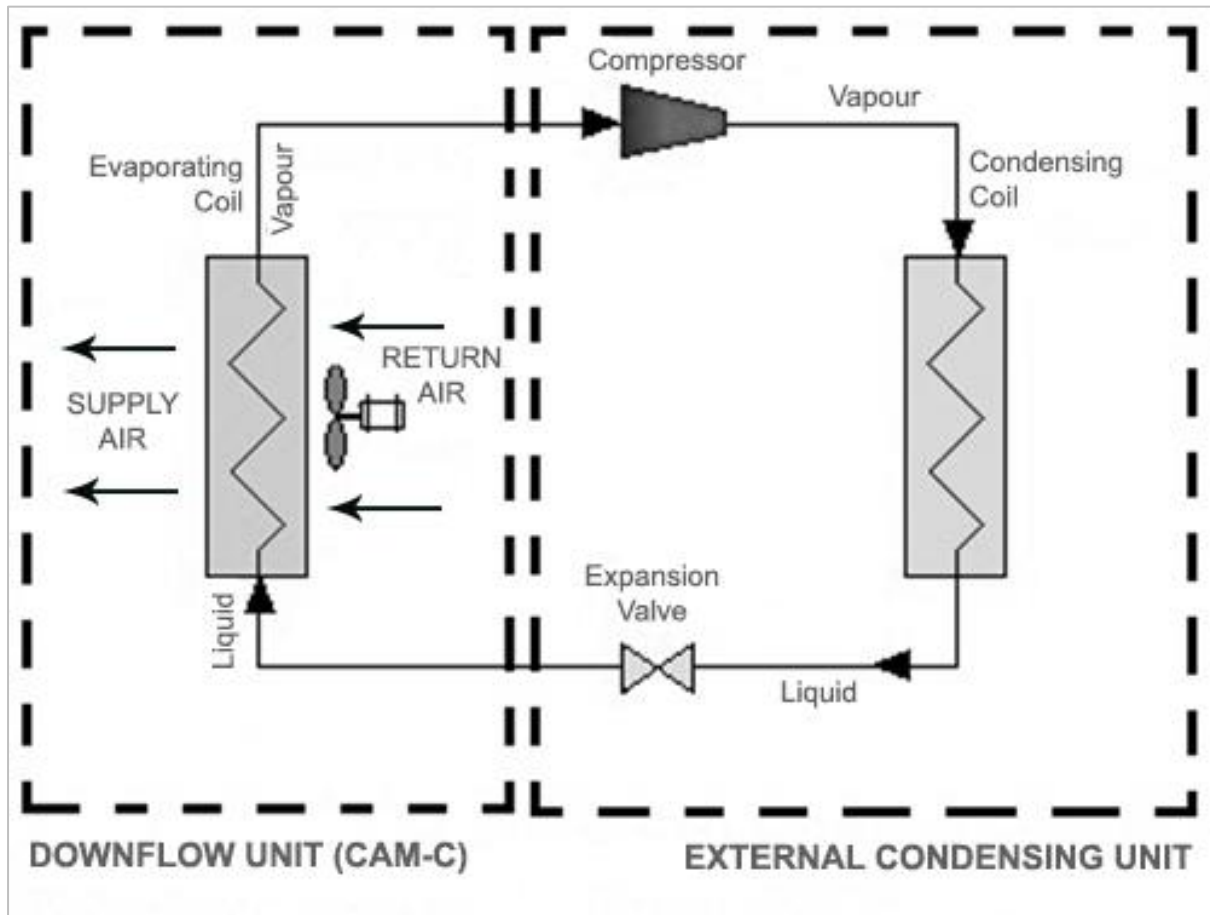

Typical coil selections are made for R410a refrigerant. In the event of high external temperatures, it is recommended to use R134a refrigerant, in which case the number of rows and pipe connections could change.

Section Two: Technical Data

2.0 Overall Dimensions and Unit Weights

CAM-C (DX) 15

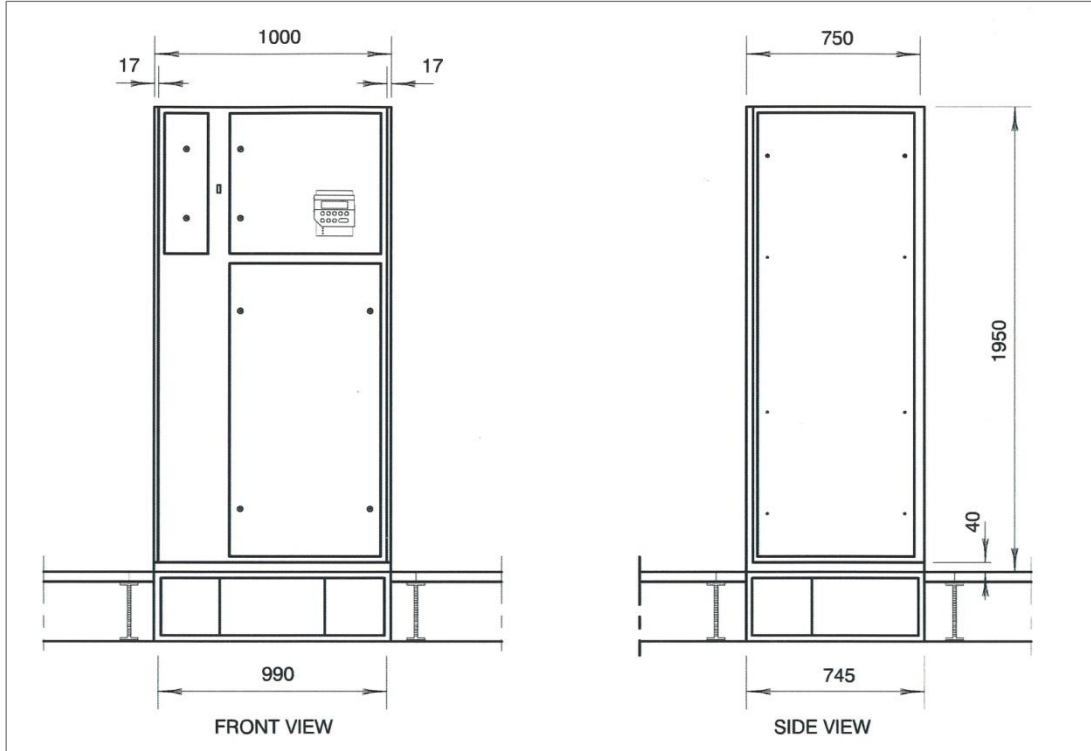

CAM-C (DX) 25

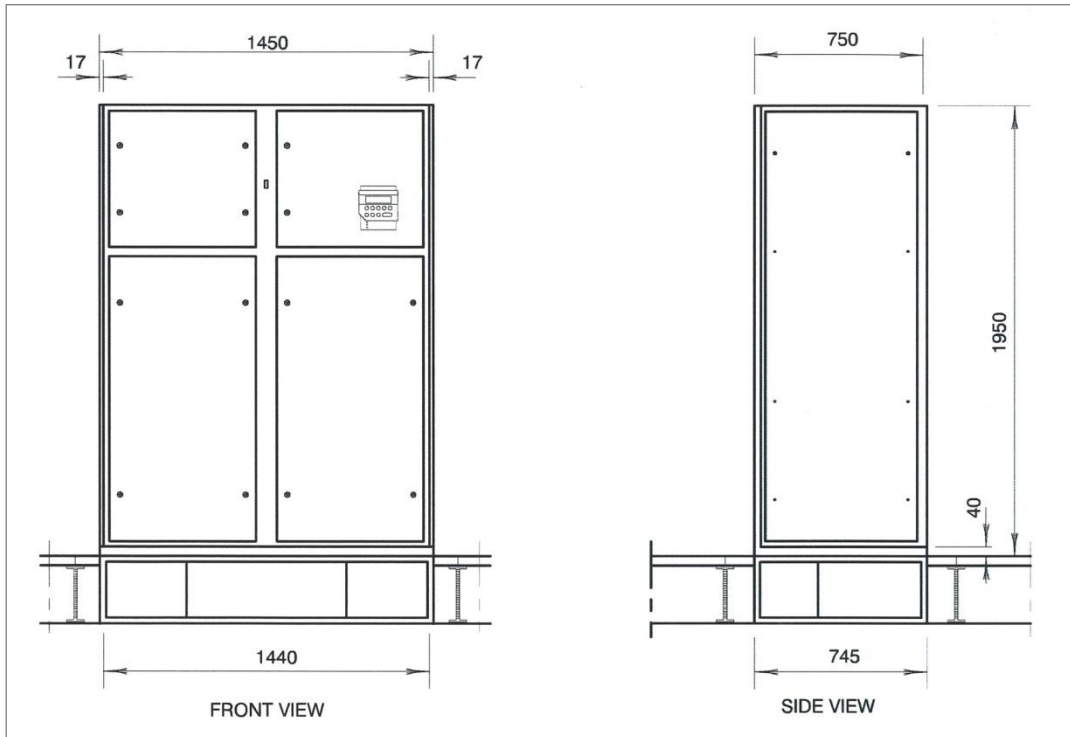

CAM-C (DX) 35

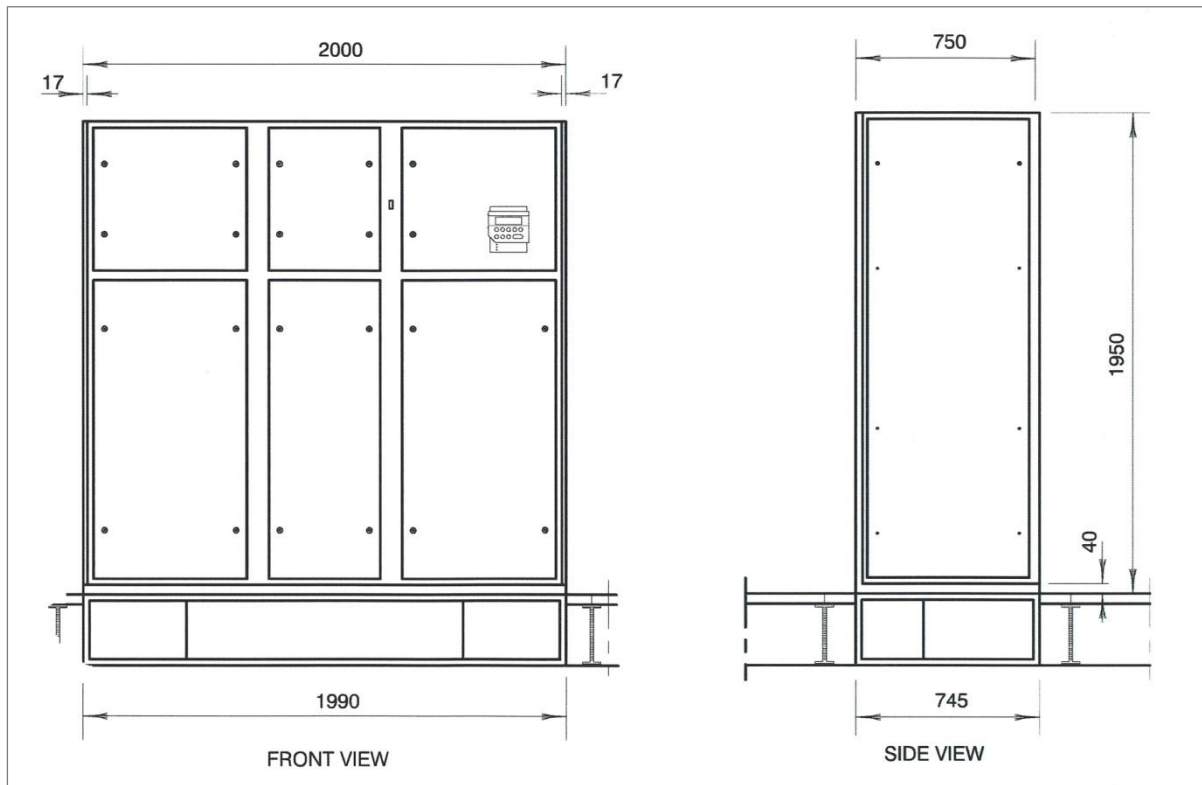

CAM-C (DX) Unit Weight (Indicative)*

Model	Maximum Weight
CAM-C (DX) 15	282 kg
CAM-C (DX) 25	385 kg
CAM-C (DX) 35	500 kg

* The weights do not include outdoor units

2.1 Opening in the Raised Floor and Service Area

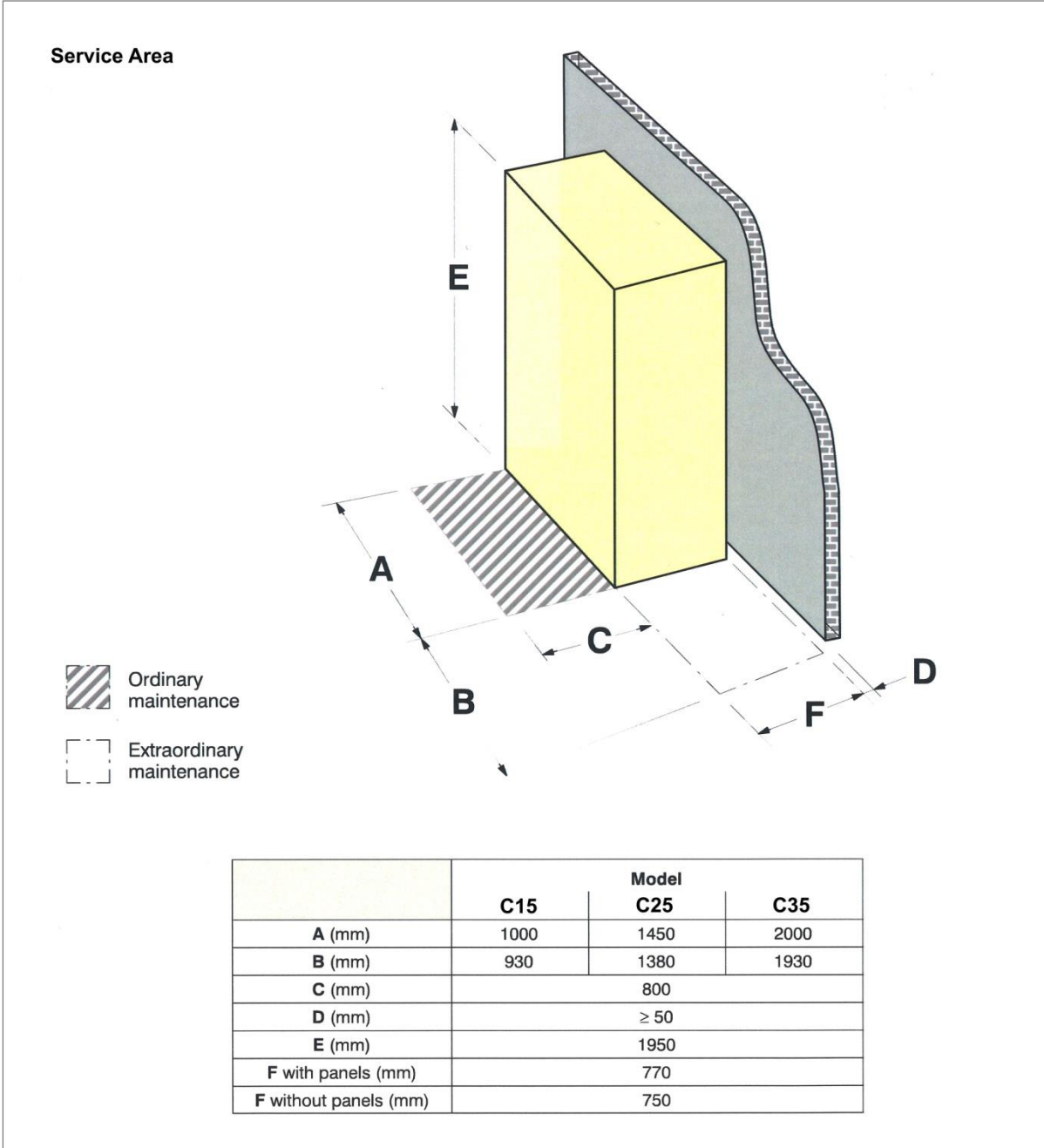

2.2 Baseframe Configuration

There are two types of baseframes:

- TP model (triangular plate)
- RP model (rectangular plate)

Using TP and RP baseframes it is possible to obtain six different configurations:

DF open, DF close, CR, CL, FL and DL.

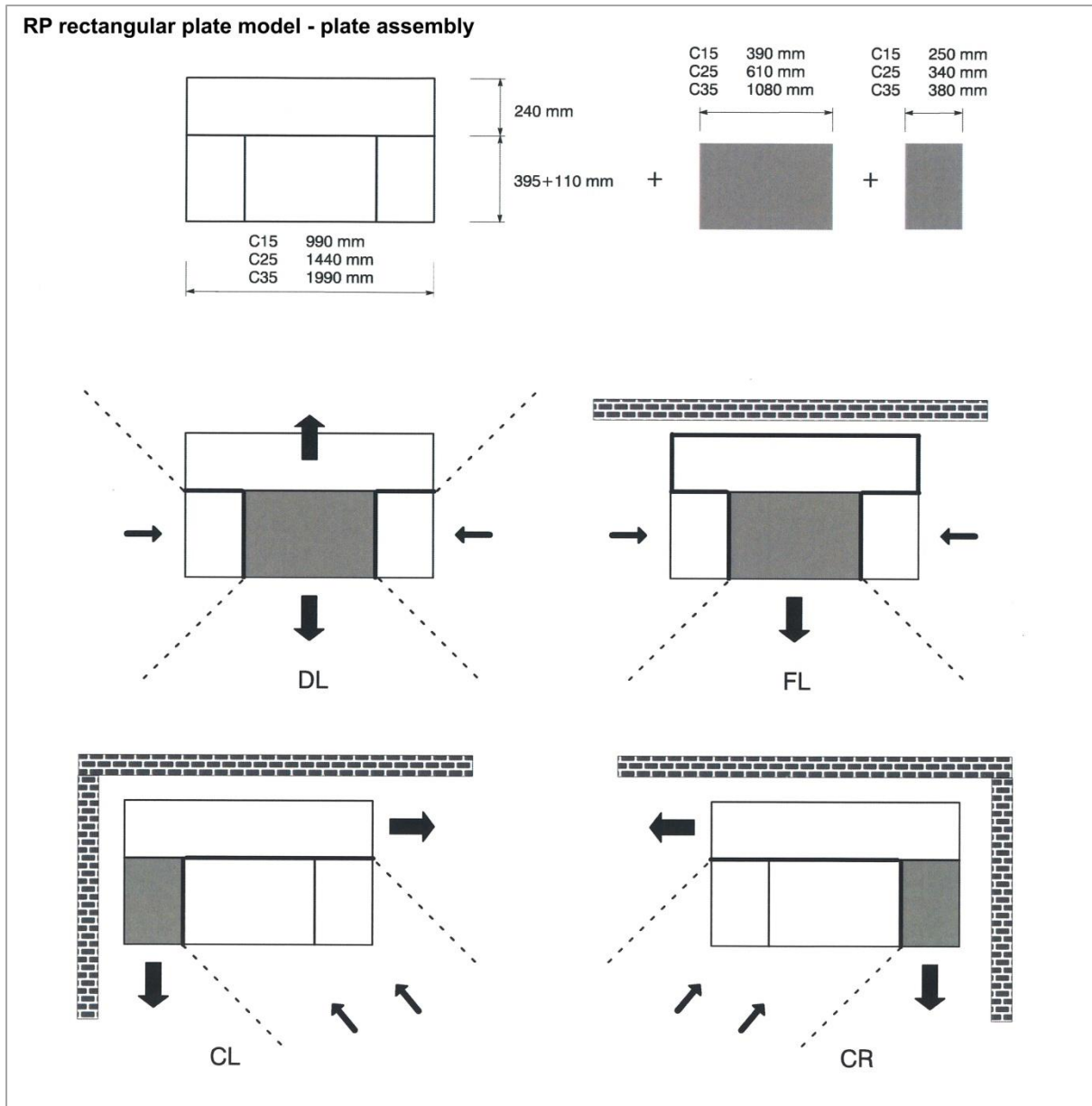

TP Triangular plate model - plate assembly

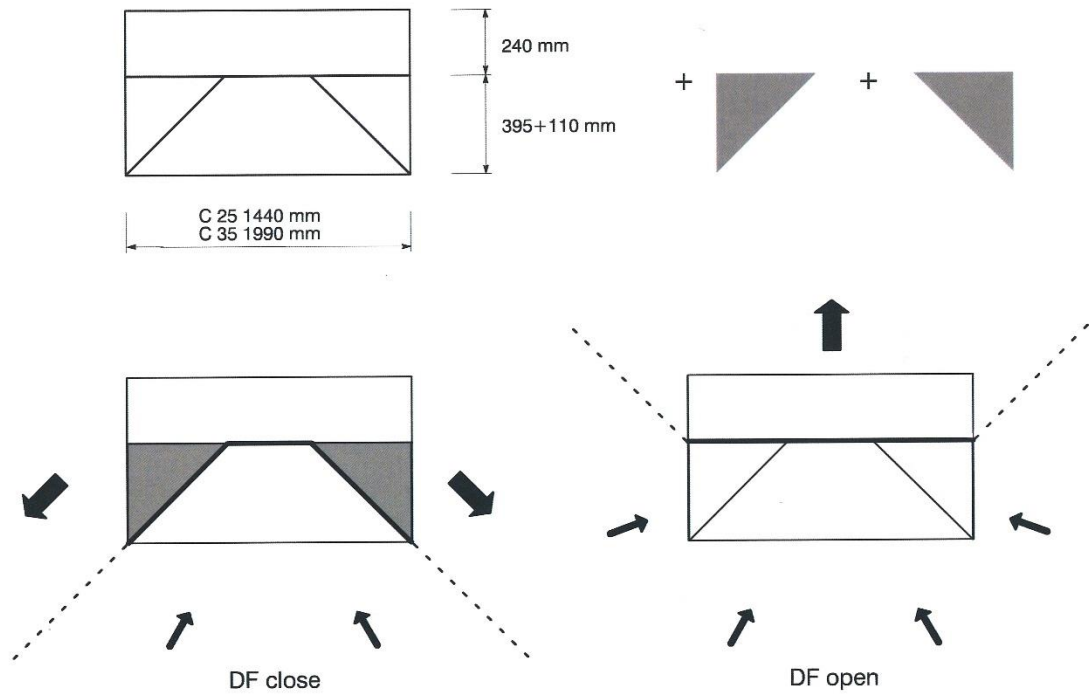

Please refer to the outdoor unit product manual for respective installation and service area information.

2.3 Noise Data

Test Conditions

All the measurements have been carried out under steady test conditions. The instrument used is a Bruel & Kjaer sound meter type 2203 equipped with an octave band filter type 1613 and condenser microphone type 4145 (according to IEC publications). The background noise level was at least 10 dB lower than the machine level at any frequency. The instrument was positioned 1.5 metres above the ground level in front of the machine at a distance of two metres.

Noise data are referred to the following conditions:

- Free field conditions
- CAM-C (DX) positioned close to the wall
- Clean filters
- Room ambient temperature 26°C, 50% R.H.

Sound pressure level is given according to ISO recommendation 1996 – 1971 (E) appendix Y.

Noise data refer to free field conditions: the noise level in the room should be calculated in accordance with the actual site and installation conditions which will affect the resultant noise in the space.

CAM-C (DX) Sound Pressure Level dB (A) (Indicative)

CAM-C (DX)15	Air flow (m3/h)	1500	2000	2500	3000	3500	4000		
	SPL base version	33	34	35	39	41	42		
	SPL add. panels	31	32	33	37	40	41		
CAM-C (DX)25	Air flow (m3/h)	3500	4000	4500	5000	5500	6000	6500	7000
	SPL base version	36	39	41	42	44	45	46	47
	SPL add. panels	35	38	40	41	42	43	44	45
CAM-C (DX)35	Air flow (m3/h)	6000	6500	7000	7500	8000	8500	9000	9500
	SPL base version	38	39	41	42	44	45	47	48
	SPL add. panels	37	38	40	41	43	44	45	46

2.4 Electrical Data

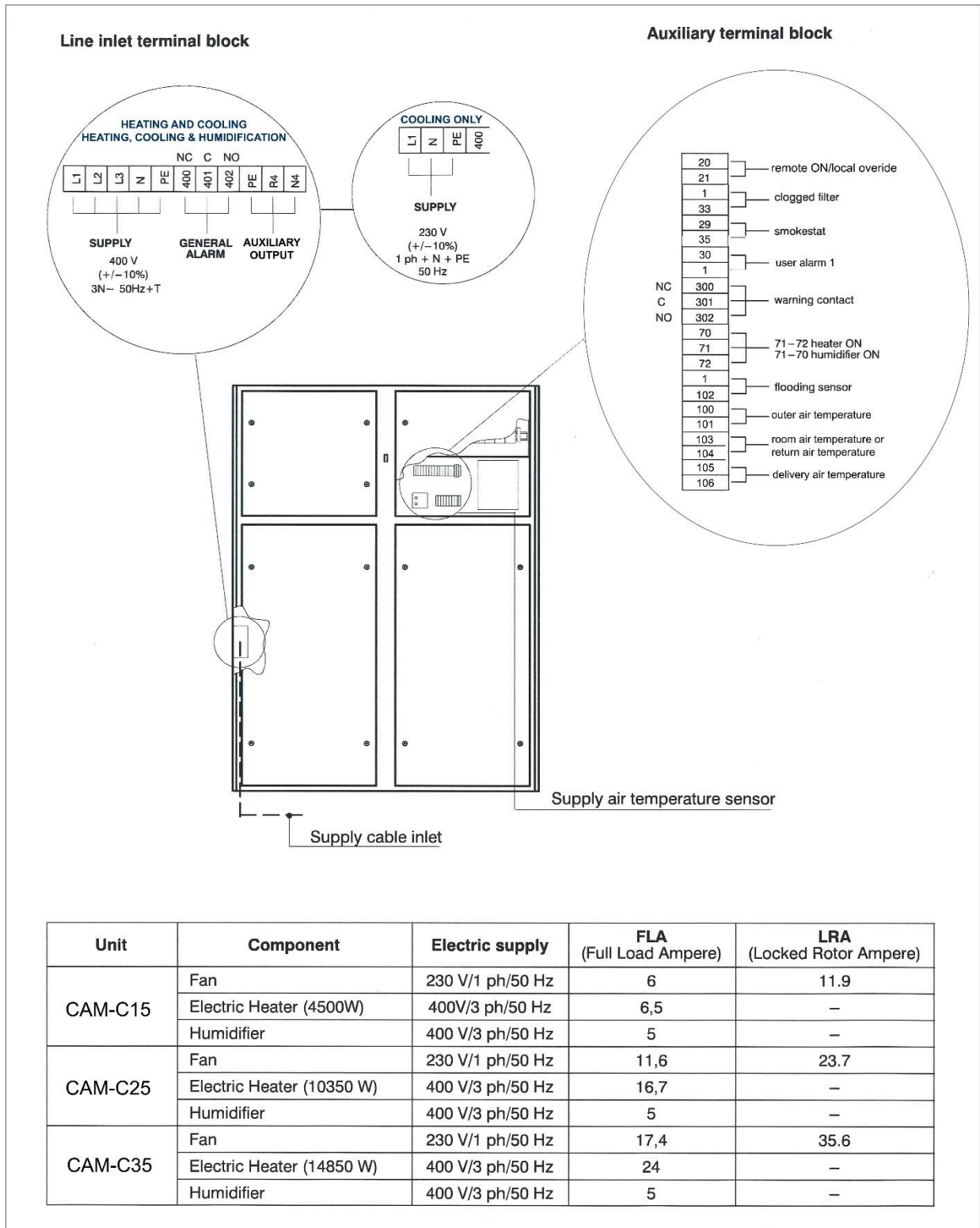

Note: Electrical Data supplied above is for AC fans only.

For outdoor unit electrical data please refer to the unit product manual.

2.5 Pipe Connections

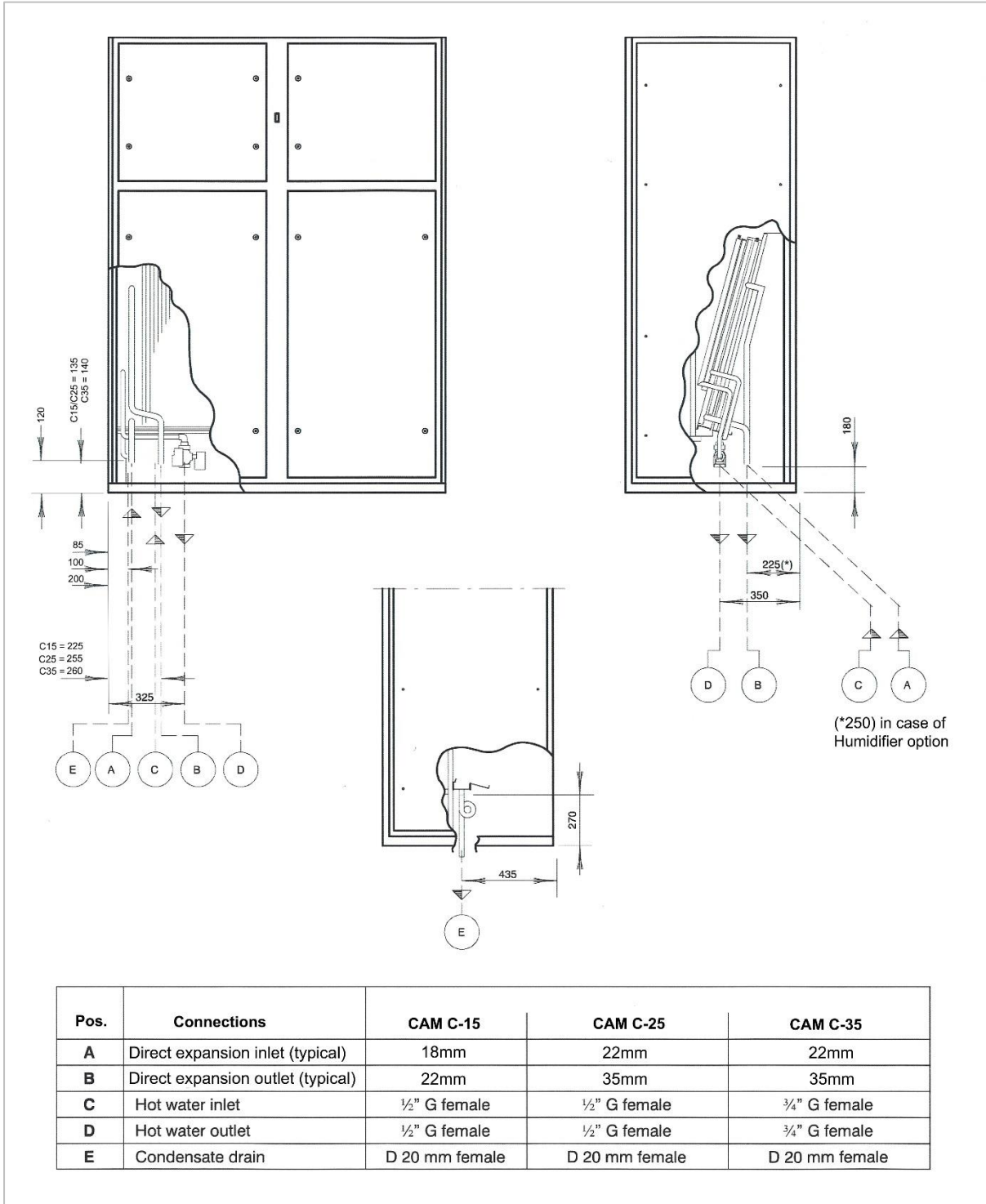

Note: Hot water coils may be supplied when full humidity control is required. Alternatively electric reheat coils can be supplied.

Water Connections – humidifier (optional)

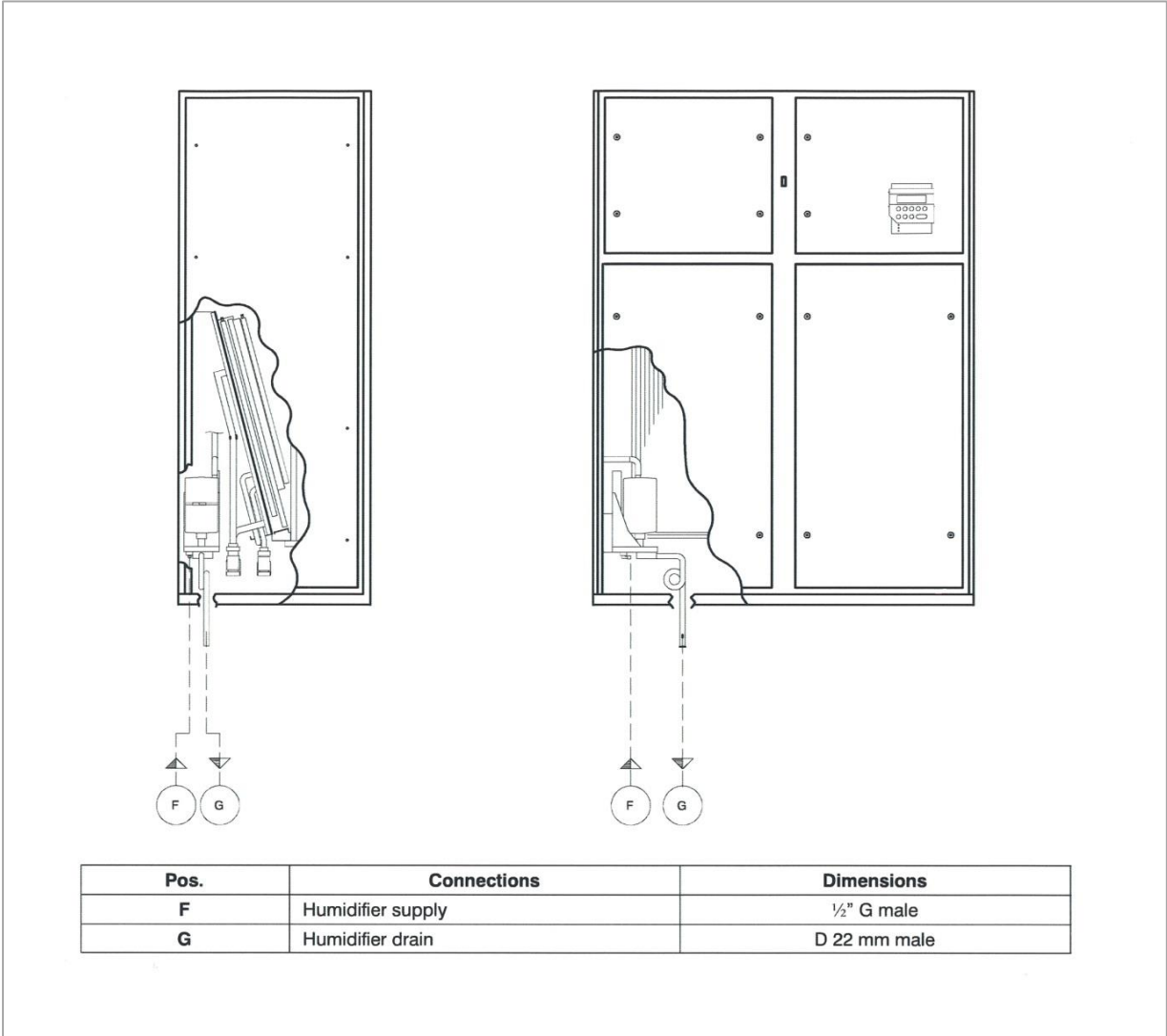

2.6 Instrument Installation

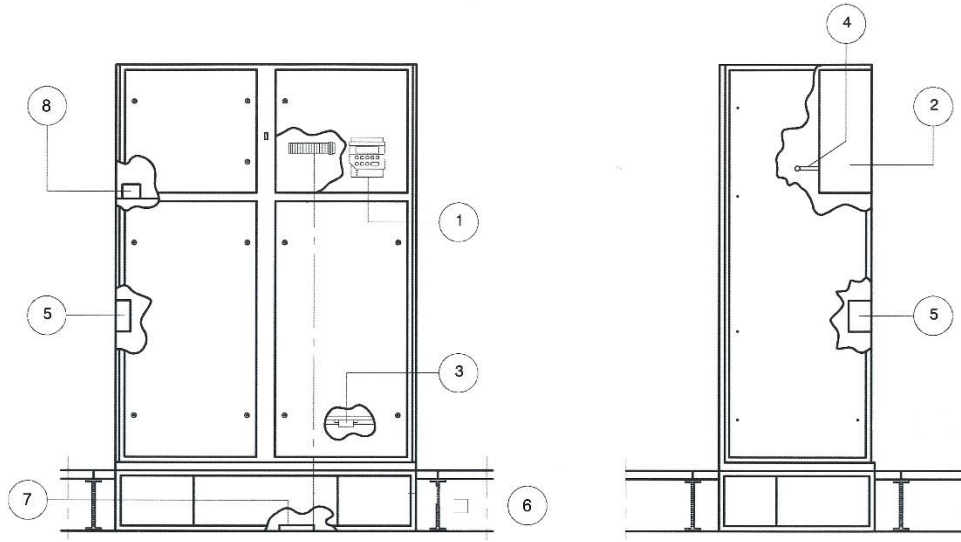

Pos.	Standard	Installation
1	Flexmatic visual display	Unit front
2	Electrical Panel	Inside unit
3	Return air temperature + humidity sensor	Inside unit
4	Airflow sensor	Inside unit
5	Terminal block electrical supply	Inside unit
6	Supply air temperature sensor	Outside unit
7	Sensor for liquistat	Outside unit
8	Clogged filter sensor (CF)	Inside unit

AET Manufacturing (UK) Ltd, The Center, 201-203 London Road, East Grinstead, West Sussex, RH19 1HA
+44 (0)1342 310400 aet@flexiblespace.com

flexiblespace.com

