



INSTALLATION GUIDE

Delta HLA high level alarm



www.deltamembranes.com



**THIS MANUAL SHOULD BE KEPT WITH
THE PRODUCT OR THE HOMEOWNER**

Contents

1.	Delta HLA overview	1
1.1	Delta HLA overview.....	1
1.2	Key features	1
1.3	Specification	1
1.4	Associated products.....	1
1.5	Parts includedwith Delta HLA.....	1
1.6	Volt-free contacts.....	1
1.7	Technical information	1
1.8	Dimensions	1
1.9	Float kits.....	2
1.9.1	Mini Float Kit	2
1.9.2	Sump Float Kit.....	3
2.	Site preparation and installation	5
2.1	Advisory	5
2.2	Intended use	5
2.3	Location.....	5
2.4	Installation.....	6
2.4.1	Mounting the Delta HLA panel.....	6
2.4.2	Mounting the mini float (Delta Dual V3/V4/V6).....	7
2.4.3	Connecting the mini float to the Delta HLA.....	8
2.4.4	Mounting the sump float (Delta Foul V3, Delta 800 Series).....	9
2.4.5	Connecting the sump float to the Delta HLA.....	11
2.4.6	Connect the Delta HLA to the mains electrical supply.....	12
2.4.7	Normally open – normally closed contacts.....	13
2.5	Connecting to external devices.....	14
2.6	Internal battery.....	14
2.7	Setting up the control panel.....	15
2.7.1	Switching on for the first time.....	15
2.7.2	Setting the service interval.....	15
3.	Operation	16
3.1	Buttons.....	16
3.1.1	Test button.....	16
3.1.2	Mute button	17
3.2	LED codes and sounds	17
3.2.1	Power LED (green)	17
3.2.2	High level alarm (red).....	18
3.2.3	High level alarm recorded (yellow)	18
3.2.4	Service due (red)	18
3.3	Sounder.....	18
4.	Wiring diagrams.....	20
5.	Maintenance	22
6.	Fault finding	23
7.	Ancillaries.....	24
8.	Declarations.....	24
9.	Warranty	25
10.	Mounting plate template.....	26
11.	Commissioning details.....	27

1. Delta HLA overview

1.1 Delta HLA overview

The Delta HLA is designed to detect high water levels within packaged pumping stations and sumps. The Delta HLA is an independent high water level alarm with an 85 dB audible alarm and LED status display on the front fascia.

It acts as a warning system in the event of:

- power failure to the Delta HLA
- a high water level state in the chamber/sump
- a high water level state has been recorded
- a service due

The Delta HLA is simple to install and offers three volt-free contacts for connection to external systems.

The Delta HLA operates via either a mini or sump float switch. If the water level rises above the start point of the primary pump, the alarm float switch lifts until a point of contact is made internally. This signals to the panel that the water level is high and the panel goes into alarm. When the level drops, the switch falls which resets the alarm.

For areas where the Delta HLA may not be seen or heard, we recommend using the Delta HLA Plus.

1.2 Key features

- An internal battery ensures continuous protection in the event of mains power failure
- Quick and simple installation
- Robust and reliable high water alarm
- LED's for visual status and warning
- Mute and reset buttons
- Three volt-free contacts
- Can be retrofitted

1.3 Specification

- Low Voltage Directive, EN61010:2010.
- EMC Directive EN55014:2006, A1 and EN55014-2:2015

1.4 Associated products

- Delta Dual V3
- Delta Dual V4
- Delta Dual V6
- Delta Foul V3
- Delta 800 Dual V3
- Delta 800 Dual V4
- Delta 800 Dual V6
- Delta 800 Single Foul V3

1.5 Parts included with Delta HLA

Delta HLA	Qty
Delta HLA alarm panel	1
16 mm cable gland	3
20 mm cable gland	1
Installation and operating guide	1

The Delta HLA should be purchased with a Mini Float Kit DMS (Section 1.9.1) or a Sump Float Kit (Section 1.9.2) depending on the pumping station being installed.

1.6 Volt-free contacts

The Delta has three volt-free for connection to remote telemetry or a building management systems. They can be set to Normally Open (NO) or Normally Closed (NC) depending on external system requirements.

- High level volt-free contact
- Power fail volt-free contact
- Service due volt-free contact

1.7 Technical information

Delta HLA	
Power supply	230 V AC 50Hz
Rated power	<10 VA
Internal battery	6V, 1.3 Ah
Sound alarm level	85 dB
Power cable length	1 m
Weight	0.5 kg
Material	ABS
Colour	Grey

1.8 Dimensions

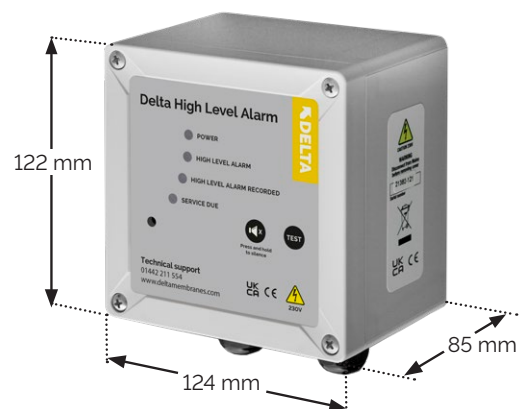

Figure 1. Panel dimensions.

1.9 Float kits

1.9.1 Mini float kit

Mini Float Kit	Qty
Mini float switch, 5 m cable	1
Delta Float Shroud	1
Cable tie	2

Suitable for:

- Delta Dual V3
- Delta Dual V4
- Delta Dual V6

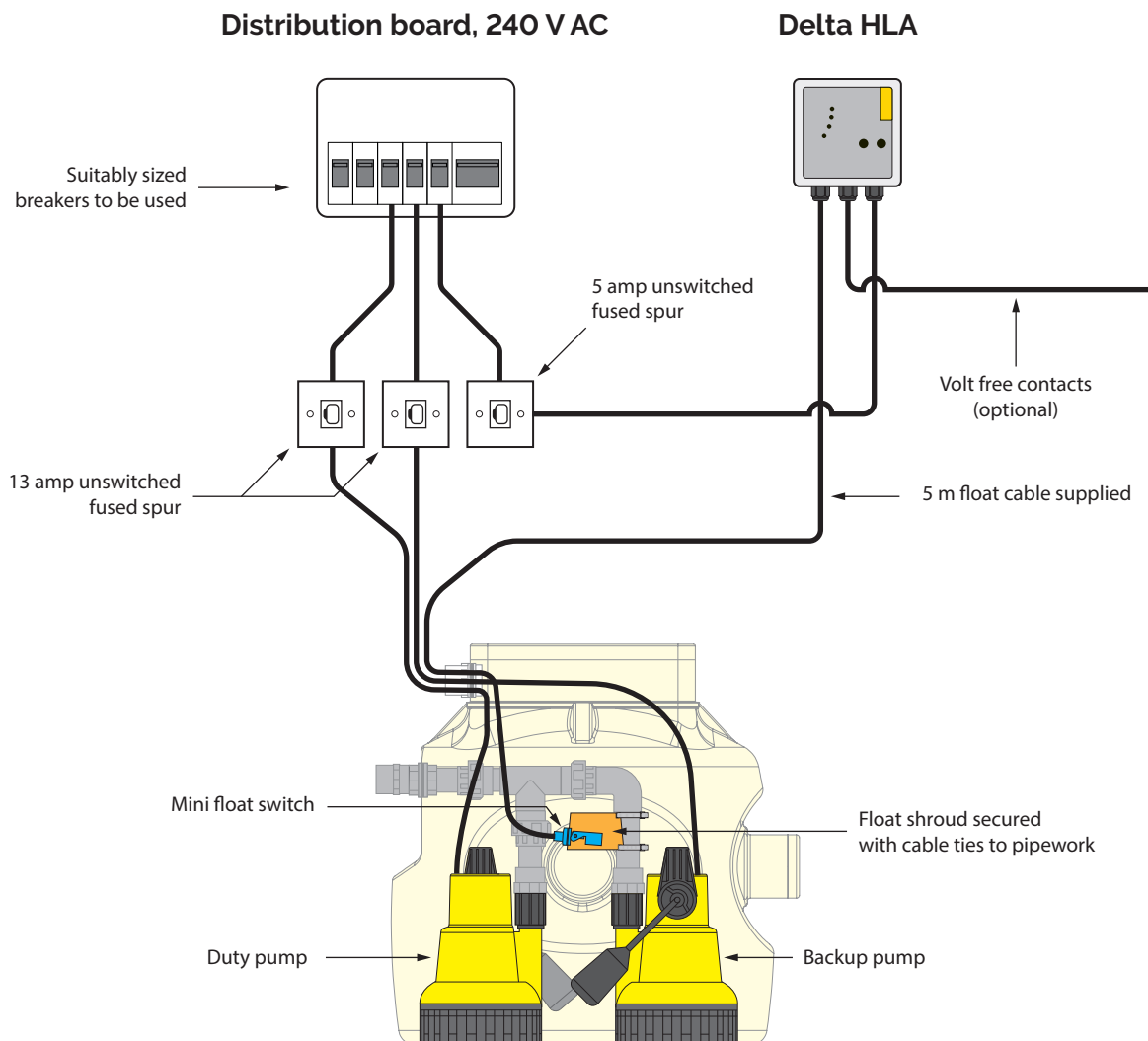

Figure 2a. Example Delta HLA + Mini Float Kit installation.

1. Delta HLA overview

1.9.2 Sump float kit

Sump Float Kit	Qty
Sump float switch, 10 m cable	1
Counterweight	1
20 mm cable gland	1
Cable tie	1

Suitable for:

- Delta Foul V3
- Delta 800 Dual V3
- Delta 800 Dual V4
- Delta 800 Dual V6
- Delta 800 Single Foul V3

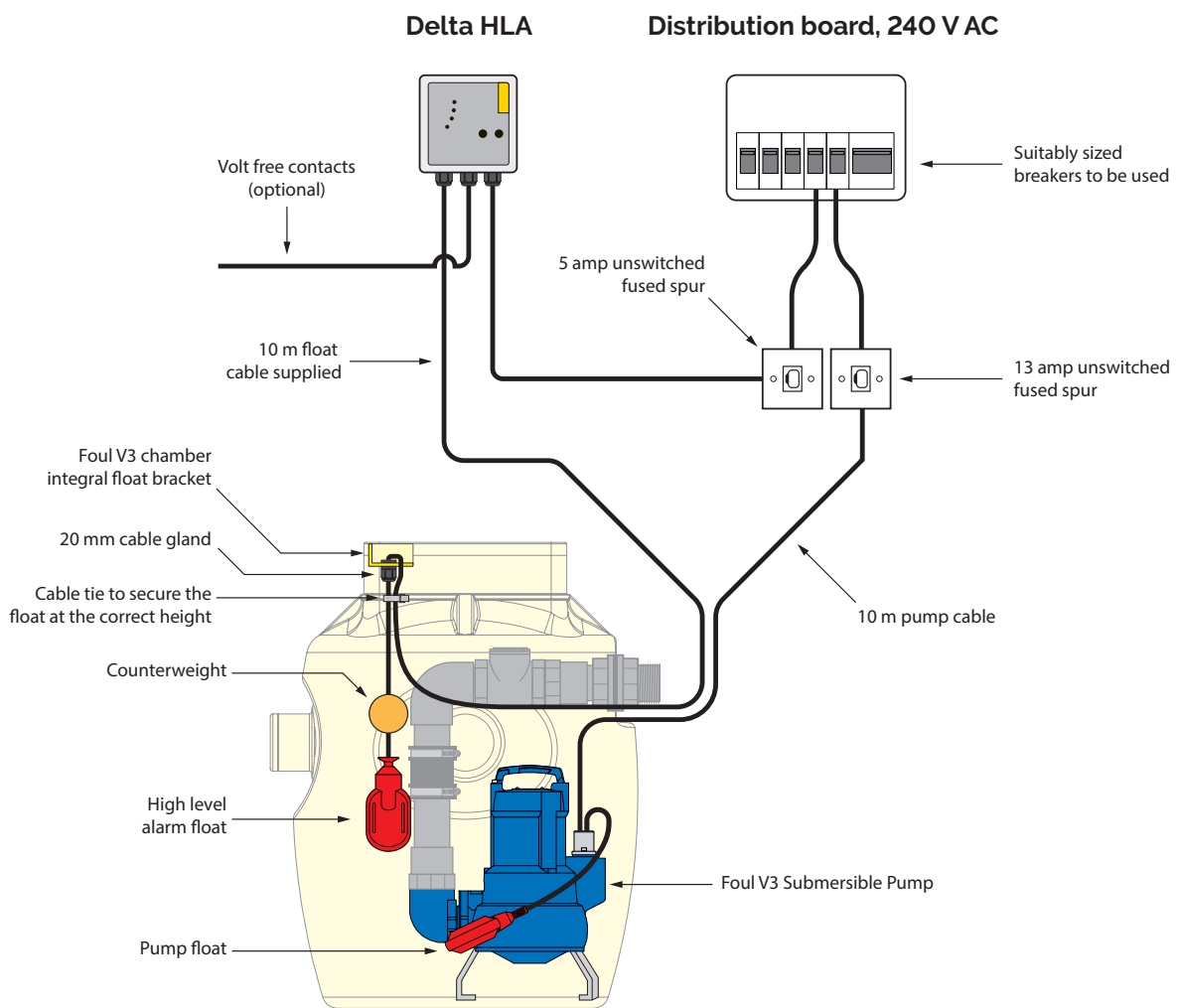

Figure 2b. Example Delta HLA + Sump Float Kit installation (Delta Foul V3).

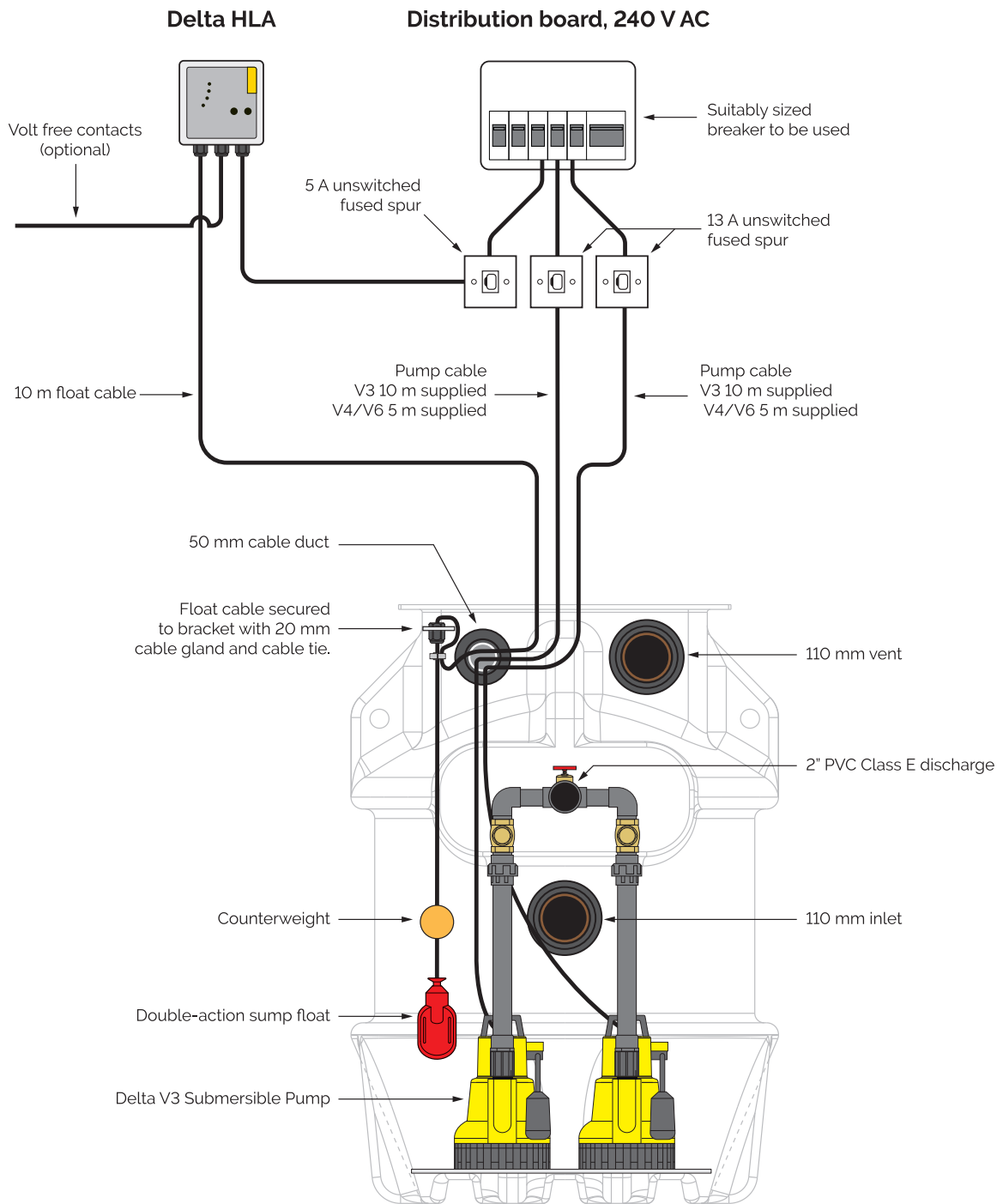

Figure 2c. Example Delta HLA + Sump Float Kit installation (Delta 800 Dual V3).

2. Site preparation and installation

2.1 Advisory

All products are manufactured and developed to the highest standards and assembled with precision and care. Each product has been rigorously tested. We constantly strive to develop our products to provide you with the most innovative products possible.

Please read these installation and operating guidelines carefully prior to installation. These guidelines contain important information and hazard warnings, which will enable you to install and operate your product safely, economically, and reliably.

Only qualified personnel should carry out the installation in accordance with the latest IET wiring regulations BS7671. All works should be in line with the Health and Safety at Works Act 1974.

It is important to note that these guidelines are for guidance only and it is the installer's responsibility to satisfy themselves that the installation procedure is in accordance with good practice, this will then eliminate any potential damage to the product during or after installation.

If you are unsure on any point, then please contact Delta Membranes on 01992 523 523 between 8am and 5pm, Monday to Friday or by email at info@deltamembranes.com for more information.

2.2 Intended use

This Delta HLA is designed for use indoors or in a suitable waterproof outdoor enclosure. Under no circumstances should the product be installed outdoors without suitable protection from both water and extreme temperatures (operating temperature -10°C to +40°C).

2.3 Location

Select a suitable location for the Delta HLA panel, taking into account that it must be located within 5 m (10 m if using the sump float switch) of the base of the pump chamber/sump, through the cable duct to the Delta HLA panel. It must be located in a dry area where the panel is audible and accessible by the end user. If you need to mount the panel further away from the pump chamber/sump, please contact Delta Membranes on 01992 523 523 between 8am and 5pm, Monday to Friday or by email at info@deltamembranes.com for more information.

When siting the panel please consider the Noise Pollution Act.

2.4 Installation

2.4.1 Mounting the Delta HLA panel

Before you mount the panel you will need to drill a hole into the panel for volt-free contact(s) cabling (if required).

- The mini float switch or sump float switch uses the M16 cable gland (supplied and installed as standard).
- The power cable uses the M16 gland (supplied and installed as standard).
- For the volt-free contacts, you will need to drill the appropriate diameter hole as shown in Figure 3 to add the M16 or M20 cable gland. The cable gland required would depend on the diameter of signaling cable used.

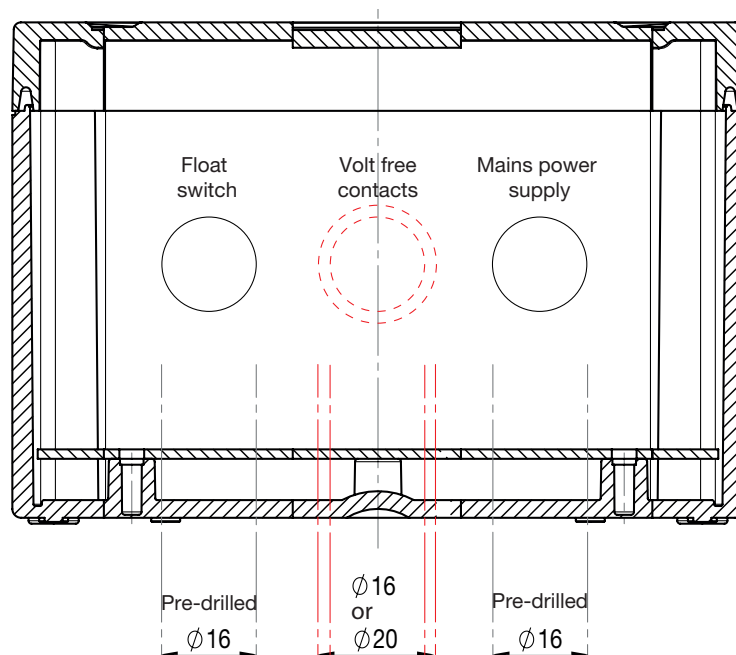

Figure 3. Drilling the mounting panel

Mount the panel to a wall or backboard using the mounting points located at the back of the panel using appropriate screws and wall plugs for the surface. Please see Figure 23 for the mounting plate template.

2. Site preparation and installation

2.4.2 Mounting the MINI float (Delta Dual V3/V4/V6)

Please refer to the specific installation and operating guidelines for the chamber/sump when installing the float switch.

The mini float switch is supplied with a 5 m cable. If you require more than 5 metres please contact Delta Membranes on 01992 523 523 between 8am and 5pm, Monday to Friday or by email at info@deltamembranes.com for assistance.

1. The mini float switch should be positioned between the activation points of the two pumps, as shown in Figure 4. This will cause the alarm to trigger if Pump 1 has failed, before Pump 2 empties the chamber. This periodic triggering is a useful indicator that there is a fault in the pumping station.
2. The mini float switch should be installed in the float shroud. The float shroud should be positioned on the vertical pipework of the rear pump so that it butts up to the base of the elbow and secured with cable ties. See Figure 5.
3. When positioning the mini float switch insert the float cable through the green washer.
4. Place the mini float switch into position with the activation arm located in the upwards position as shown in Figure 6.
5. Insert the mini float cable through the blue plastic washer and nut and tighten fully.
6. Cable to be drawn through cable duct between the chamber/sump and control panel location for removal at a later date.

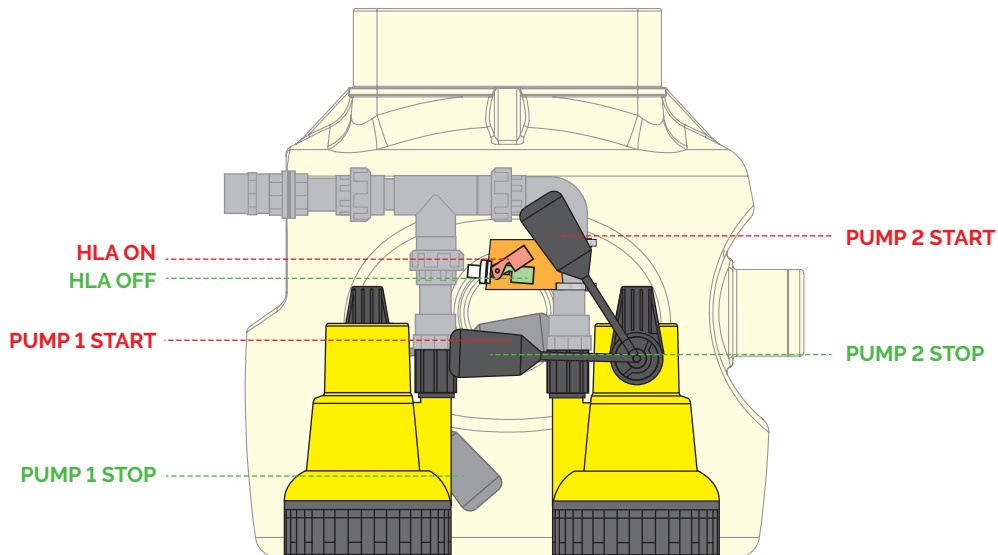

Figure 4. Mini float switch on and off positions.

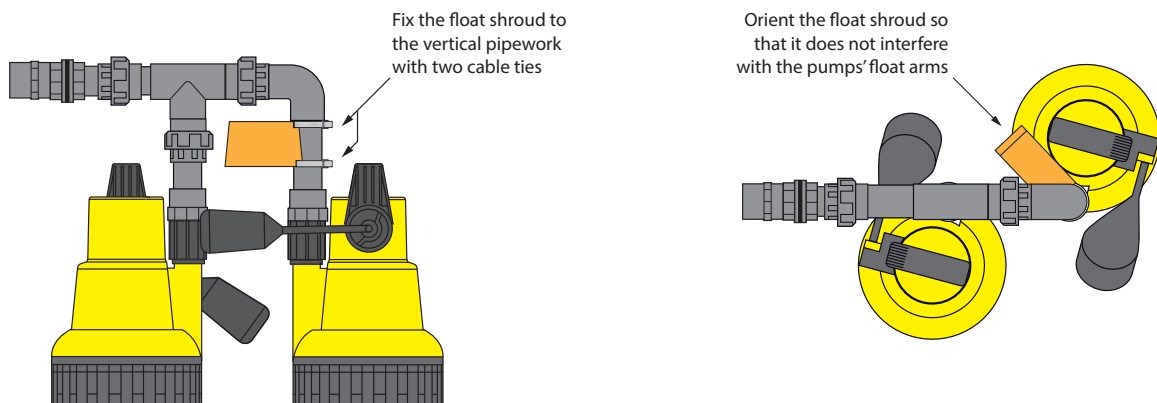

Figure 5. Fixing and orienting the float shroud.

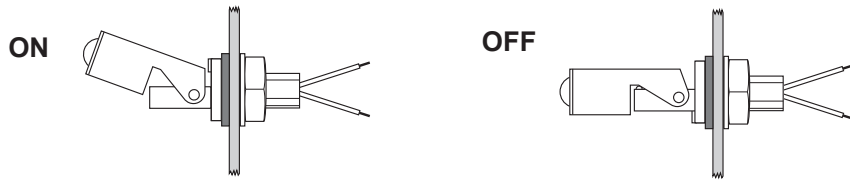

Figure 6. Mini float switch on and off positions.

2.4.3 Connecting the MINI float to the Delta HLA

1. Loosen the float switch cable gland located on the underside of the Delta HLA panel, as shown in Figure 3.
2. Draw the mini float switch cable through the cable gland.
3. Connect the brown core to the positive and the blue core to the negative terminal, as shown in Figure 7.

Please note, that the Delta HLA panel is factory set to a normally closed contact. The advantage is that should the mini float cable become damaged and/or disconnected the alarm will activate.

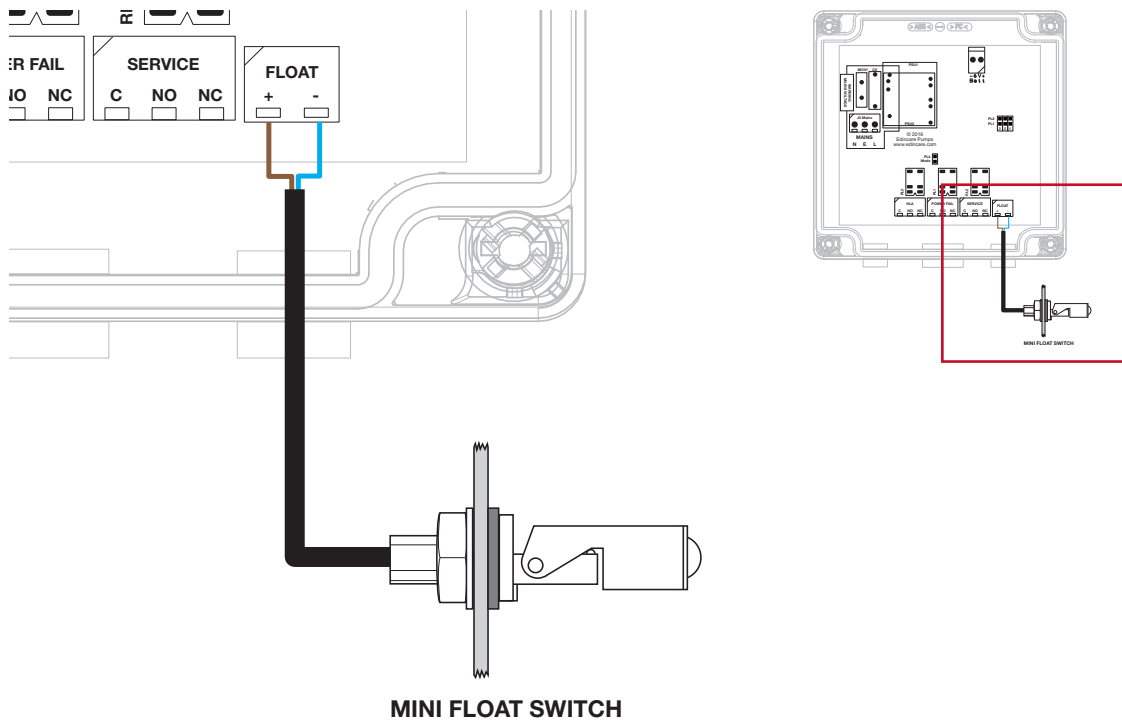

Figure 7. Connecting the mini float switch to the Delta HLA.

2. Site preparation and installation

2.4.4 Mounting the SUMP float (Delta FOUL V3, Delta 800 Series)

Please refer to the specific installation and operating guidelines for the chamber/sump when installing the float switch.

The sump float switch is supplied with a 10 m cable. Should you require more than 10 metres contact Delta Membranes on 01992 523 523 between 8am and 5pm, Monday to Friday or by email at info@deltamembranes.com for assistance.

1. Please ensure you position the sump float switch higher than the primary pump activation point contained within, as shown in Figure 8a, 8b or 8c.
2. Install the sump float switch cable securely. The sump float switch should be installed using a float bracket. The Delta Foul V3 chamber features an integral float bracket. 800 Series chambers feature a steel float bracket (see Section 7 Ancillaries).
3. Attach the counterweight approximately 70 mm from the top of the float switch. You must separate the counterweight by removing the centre screw using a 6 mm Allen key, once separated you will see two grooves, using the smaller of the grooves position the cable into place and put the counterweight back together ensuring the centre screw is tightened.
4. Pull the float cable through the M20 cable gland on the float bracket. Position the sump float switch higher than the primary pump activation point. Once the float has been positioned tighten the M20 gland.
5. Fix the cable into position using a cable tie to ensure the float doesn't drop down.
6. Cable to be drawn through cable duct between the chamber/sump and control panel location for removal at a later date.

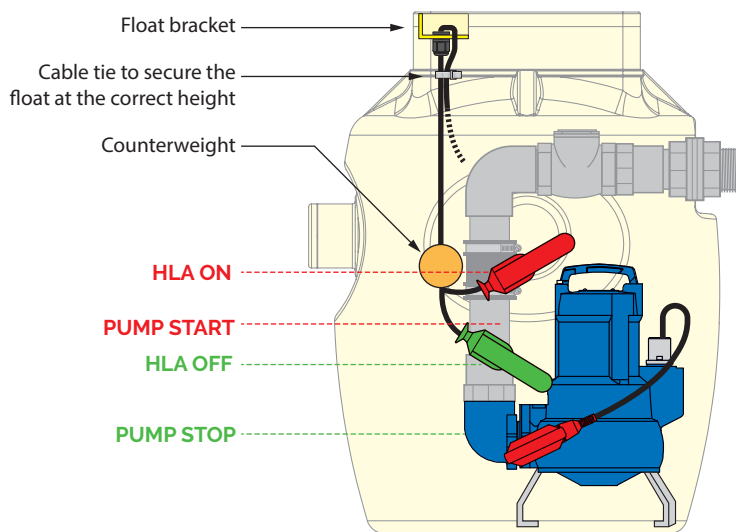

Figure 8a. Setting the switching heights of the sump float in a Delta Foul V3 Packaged Pumping Station.

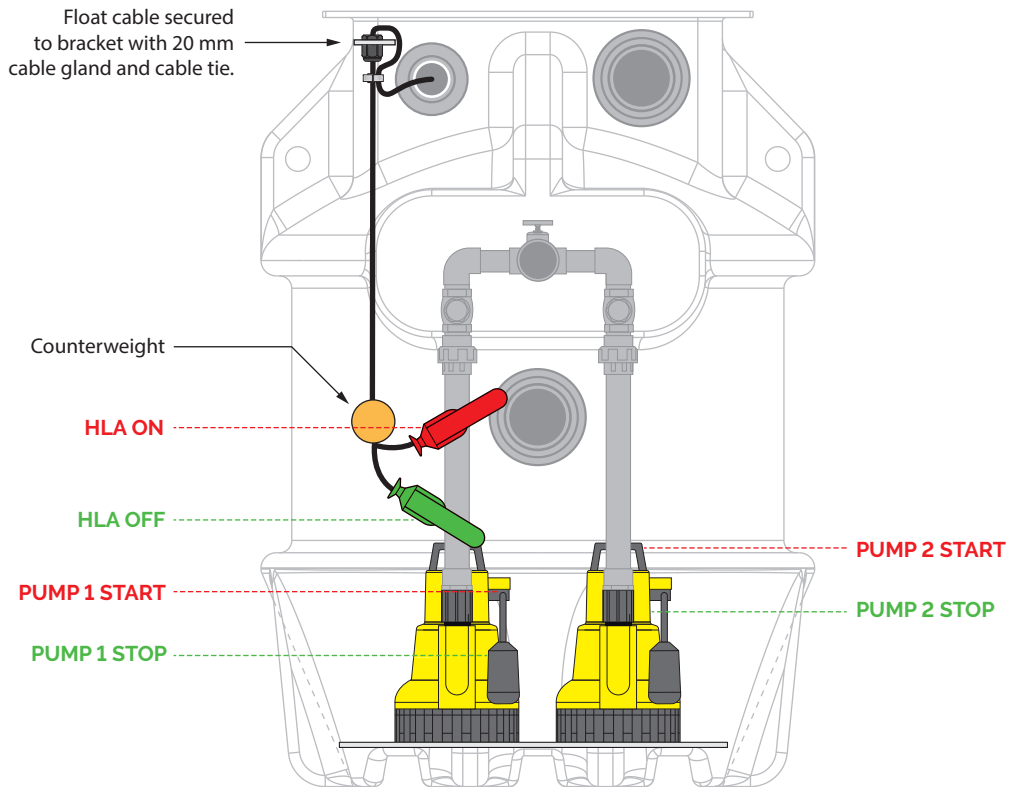

Figure 8b. Setting the switching heights of the sump float in a Delta Dual V3/V4/V6 800 Series Packaged Pumping Station.

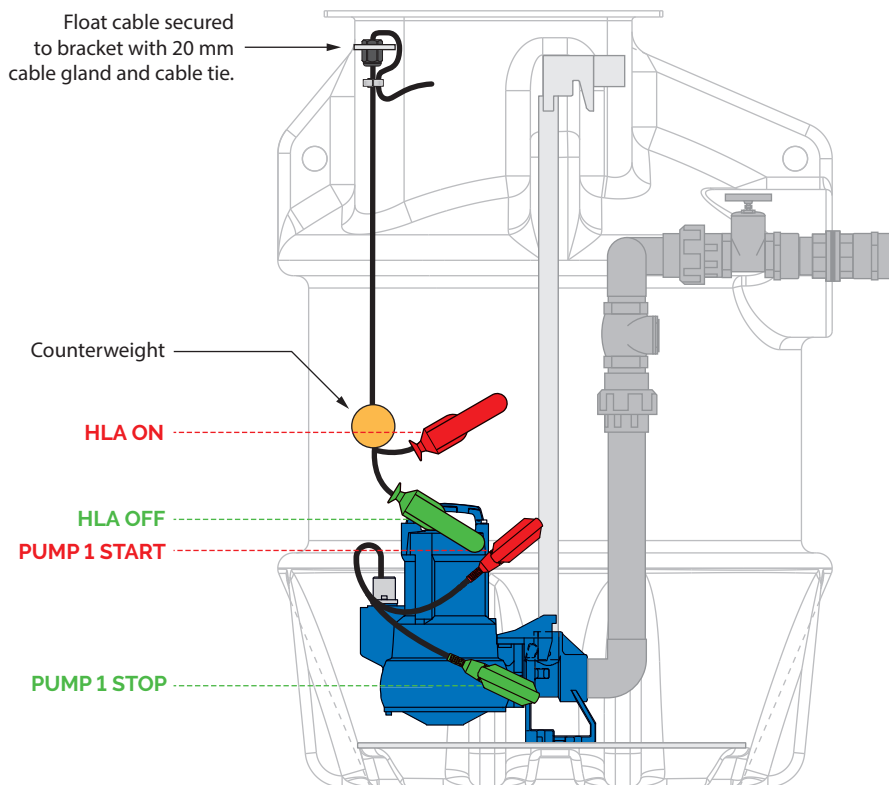

Figure 8c. Setting the switching heights of the sump float in a Delta Single V3 Foul 800 Series Packaged Pumping Station.

2. Site preparation and installation

2.4.5 Connecting the SUMP float to the Delta HLA

1. Loosen the float switch cable gland located on the underside of the Delta HLA panel, as shown in Figure 3.
2. Draw the sump float switch cable through the cable gland.
3. Connect the brown core to positive and the blue core to the negative terminal, as shown in Figure 9.
4. Ensure that the black core is isolated.

Please note, that the Delta HLA panel is factory set to a Normally Closed contact. The advantage is that if the sump float cable becomes damaged and/or disconnected the alarm will activate.

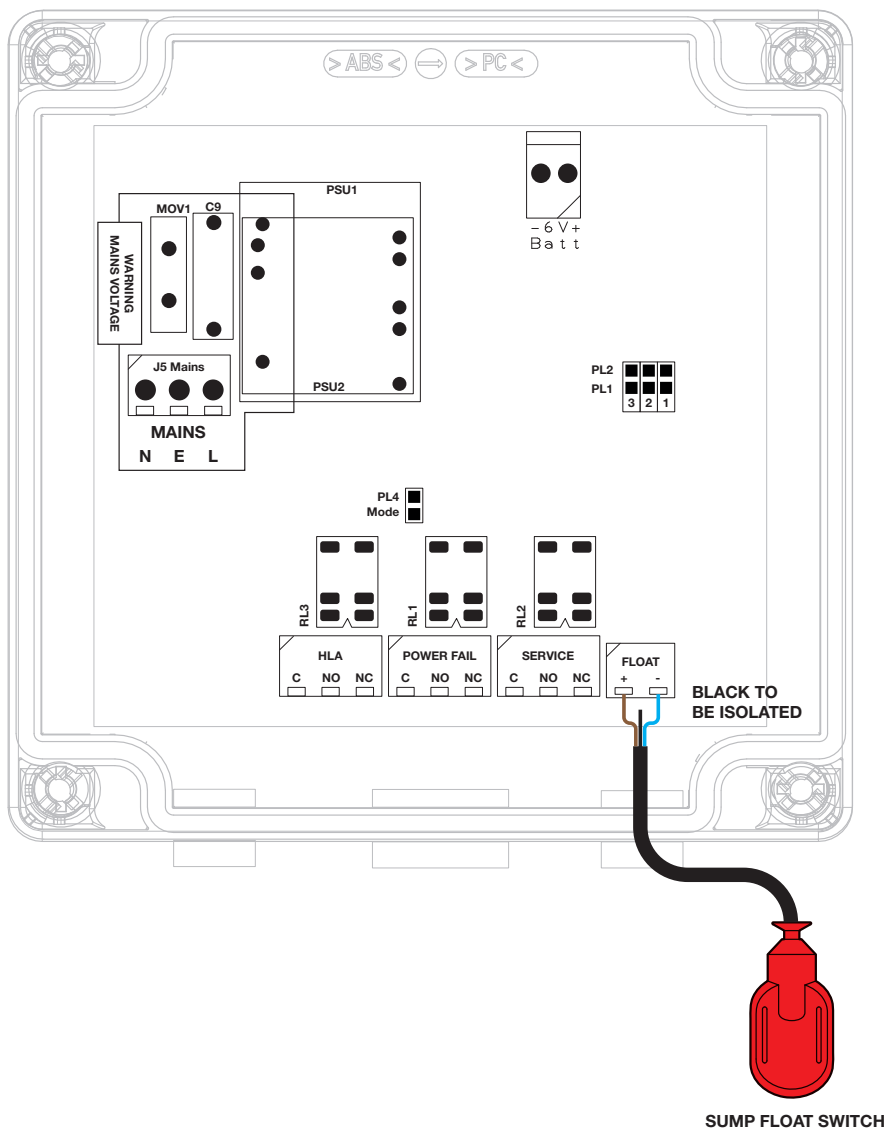

Figure 9. Connecting the sump float to the Delta HLA.

2.4.6 Connect the Delta HLA to the mains electrical supply

The Delta HLA should be connected to the mains electrical supply by a qualified person in accordance with the Institute of Electrical Engineers Regulations with the latest IET wiring regulations – BS7671. Please take into account all the electrical information as shown in Section 4 when installing the panel.



WARNING!

For connection to the mains electrical supply it is imperative that the Delta HLA is connected to a dedicated power supply and not via a ring main.

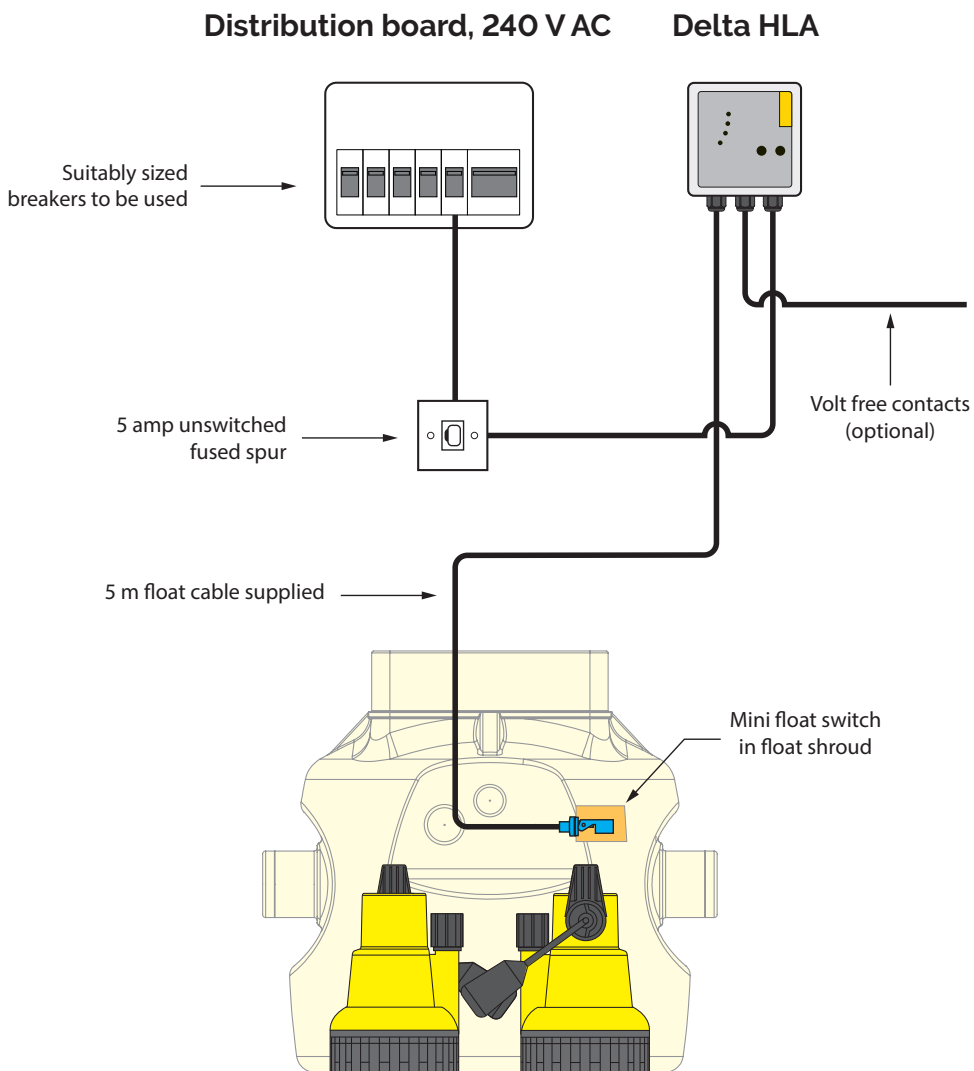

Figure 10. Connecting the Delta HLA to mains electrical supply.

2. Site preparation and installation

The panel comes pre-installed with a 1 m length of 3-core mains power cable, for connection to an un-switched fused spur (5A). The un-switched fused spur should be sited adjacent to the Delta HLA panel. Ensure that the appropriate breaker within the distribution board is clearly marked for isolation of the Delta HLA.

This work should be entrusted to a qualified electrician in accordance with the latest IET wiring regulations BS7671.

Keep the connection isolated until you are ready to test the system.

2.4.7 Normally open – normally closed contacts

The PL4 jumper on the circuit board is factory set to Normally Closed (NC) to operate the float switch. This is the correct setting, because it will trigger the alarm if the float cable becomes damaged.

However, should you need to change this to Normally Open (NO) please fit the jumper so that it bridges the contacts.

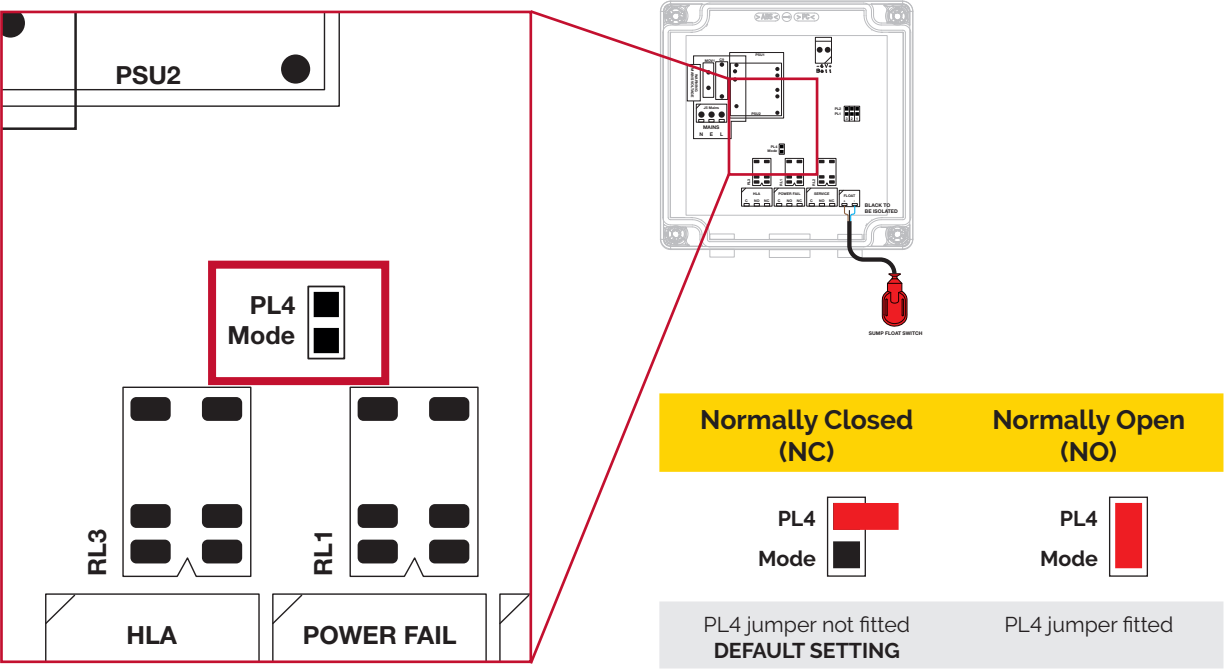

Figure 11. Jumper settings.

2.5 Connecting to external devices

The Delta HLA comes complete with three volt-free normally open (NO) normally closed (NC) terminals for connection to external devices such as a dial-out telemetry or a building management system.

Please note, the colours on the volt free cabling are for illustrative purposes only. Actual colour will depend on the cable used by the installer.

The volt free contacts are intended for use of low voltage (SELV/ELV) circuits operating a maximum of 1 amp.

High level volt free contact – This contact will send a signal to an external device such as a dial-out telemetry or building management system (BMS) if a high level situation occurs. There is the option of connecting to a NC or NO device depending on the receiving systems connections.

Power fail volt free contact – This contact will send a signal to an external device such as a dial-out telemetry or building management system (BMS) if there is a removal of mains power to the Delta HLA occurs. There is the option of connecting to a NC or NO device depending on the receiving systems connections.

PLEASE NOTE: This relay is normally energised when mains power is applied.

Service due volt free contact – This contact will send a signal to an external device such as a dial-out telemetry or building management system (BMS) when a service of the pump station is due. There is the option of connecting to a NC or NO device depending on the receiving systems connections.

For connection of the volt free contacts you must connect 1 core to the common terminal and 1 core to either the NC or NO contact. The connection of the NO or NC contact will depend on the connection on the receiving device.

Please see the wiring diagram as shown in Section 4 for further information.

2.6 Internal battery

The Delta HLA will operate for 24 hours without mains power subject to the battery being fully charged.

Please replace the internal battery every 2 years. See Section 7 for more information.

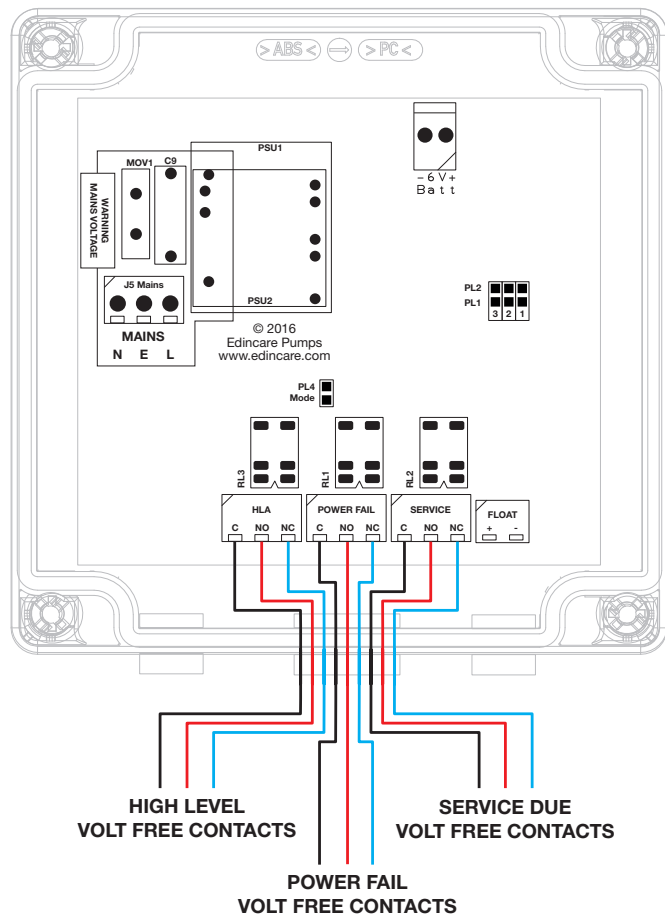

Figure 12. Volt free contacts.

2. Site preparation and installation

2.7 Setting up the control panel

2.7.1 Switching on for the first time

1. Rotate panel fascia fixing screws and release the cable glands to obtain access to the inside of the panel.
2. Make float connections as shown in Section 2.4.
3. Make volt-free contact connection (if required) as shown in Section 2.5.
4. Connect the internal battery to the PCB, the negative core will already be connected. The positive core must be attached to the positive section of the internal battery on the base of the Delta HLA panel. Once connected it will run through its starting up sequence. The green power light will flash (and the unit will beep) until the mains power supply has been connected.
5. Replace panel fascia fixing screws and tighten the cable gland before switching on from the mains power.
6. Switch on mains electrical supply. The green power light will now be permanently lit and the system is ready to monitor.
7. Remove power to the pump/s contained within the chamber/sump and allow the water level to rise until the high level float switch is activated and activates the audio/visual alarm.
8. Reset the high level alarm recorded as shown in Section 3.2.3.
9. Press the 'Test' button to simulate a HLA as shown in Section 3.1.1.
10. Once you are ready to go live with the system please set the service interval and reset the service reminder timer, as shown in Section 2.7.2.

2.7.2 Setting the service interval

The service interval is factory set to yearly. To change to quarterly or half yearly please change the jumper settings on the PCB using the information, as shown in Figure 14.

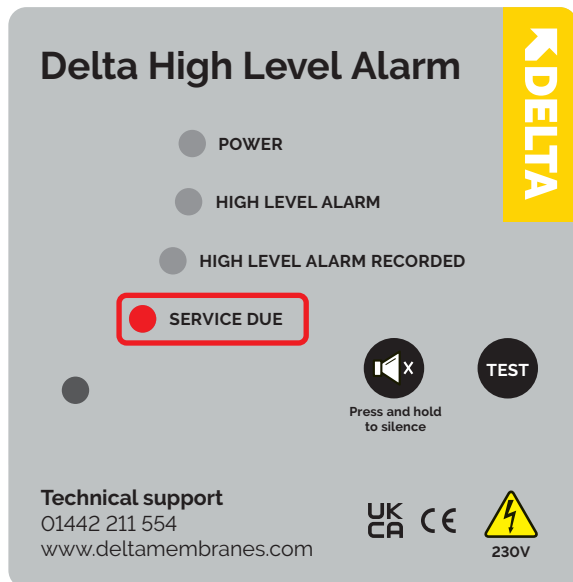

- To reset the service reminder timer, hold the mute button and press the test button five times this will reset the service reminder timer, service reminder LED and sounder.
- You will hear a number of beeps this will equal the number of months you set your service reminder too, eg. 3 beeps for quarterly, 12 beeps for yearly.

Figure 13. Setting the service intervals.

Service interval	Quarterly	Half-yearly	Annually
Number of beeps	3	6	12
Jumper 1	Not fitted	Fitted	Fitted
Jumper 2	Fitted	Not fitted	Fitted
Jumper 3	Not fitted	Not fitted	Fitted

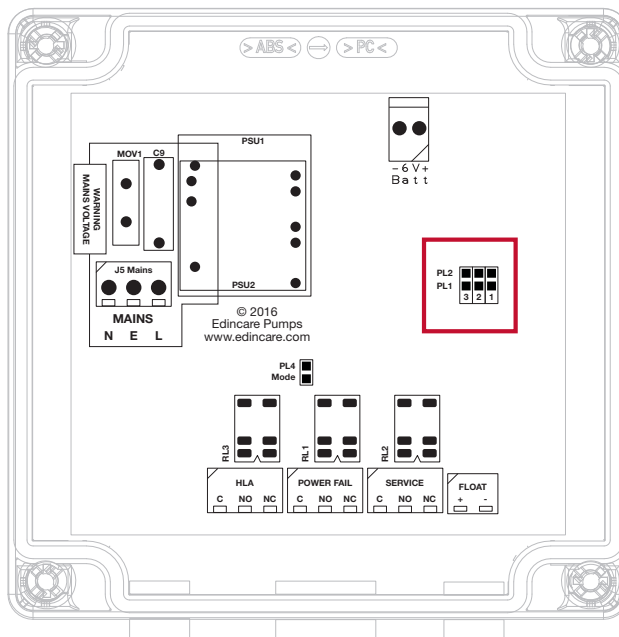
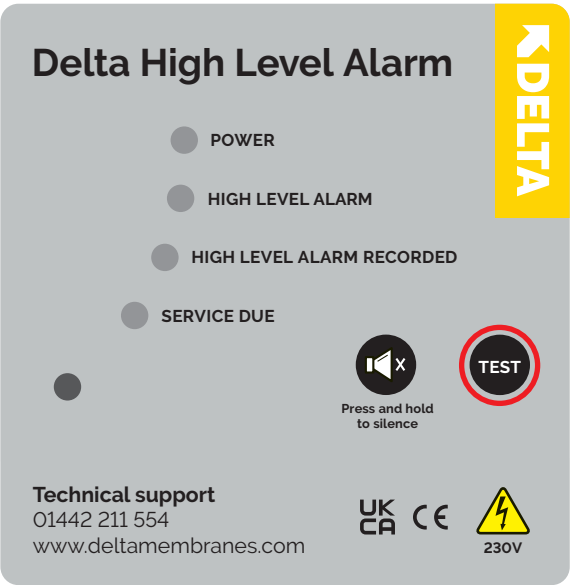

Figure 14. Setting the jumpers for the service interval.

3. Operation

3.1 Buttons

3.1.1 Test button



- If you hold the test button this will simulate a high level alarm.
- The audio sounder will beep and the HLA LED will flash.
- This will override the HLA audio sounder mute function if it has previously been activated.
- When the test button is released, the high level alarm recorded LED will NOT start flashing (unlike a "real" HLA).

Figure 15. The test button.

3.1.2 Mute button

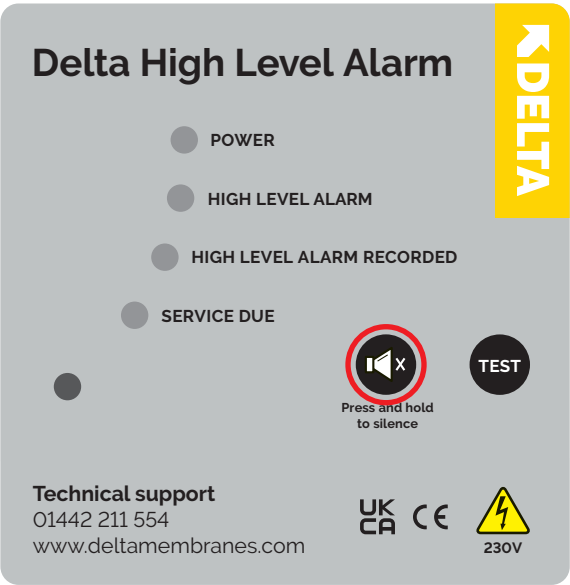

- To silence the audio sounder for 7 days, hold the mute button for 5 seconds – the sounder will beep twice to confirm and the LED which was triggered will become lit continuously for the duration of the beeps.
- Please note the HLA, power fail and service reminder LED's will continue until the system returns to its normal conditions.

Figure 16. The mute button.

3.2 LED codes and sounds

3.2.1 Power LED (green)

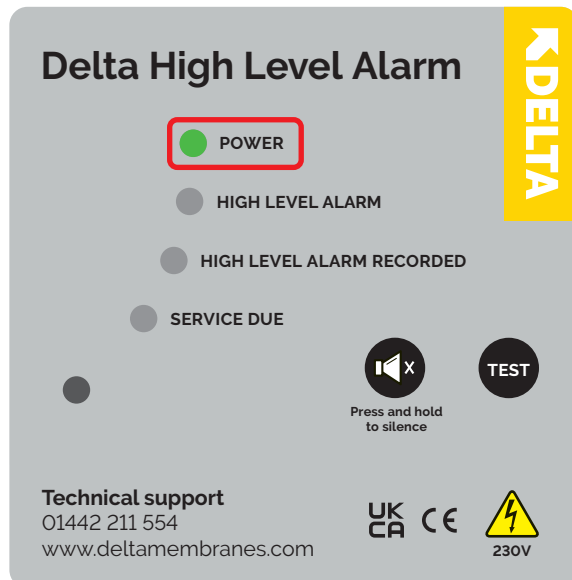

Figure 17. The power indicator.

- **Mains power present** – continuously lit.
- **Loss of mains power running on backup battery** – flash every 2 seconds. If the power fail condition returns to normal the beeps will stop automatically.

Low battery

- The system will continue to operate normally until the back-up battery discharges to a critical "low battery voltage".
- In **low battery mode** all 4 LEDs will be sequentially flashed with a 5 second pause in between.
- During this phase, the service interval unexpired time is saved as a precaution.
- Any previously activated relay will be de-energized and no beeps will be heard.

Flat battery

- If mains power is not restored, the battery will further discharge and may eventually fall below a second critical value ("flat battery").
- At this point the system will shut itself down completely.
- It will re-boot itself when the mains power returns and use the unexpired service interval time previously saved.

3.2.2 High level alarm (red)

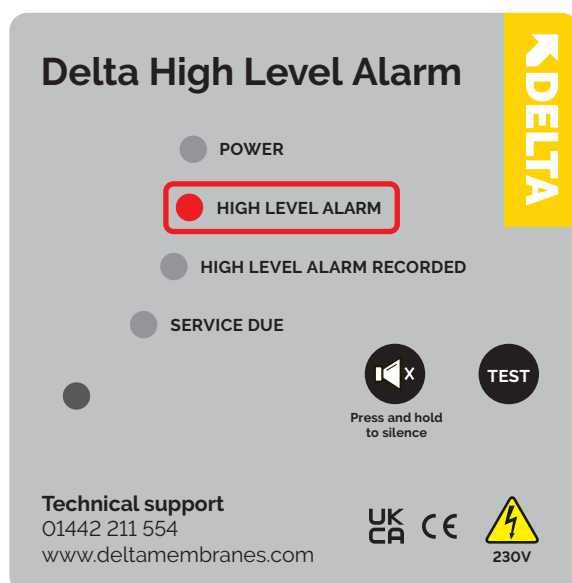

Figure 18. The high level alarm indicator.

- When the HLA triggers the system will beep every 2 seconds (this will trigger if there is a high level condition) once the high level condition returns to normal the beep will stop automatically and the LED will switch off.
- The HLA recorded will then flash yellow.

3. Operation

3.2.3 High level alarm recorded (yellow)

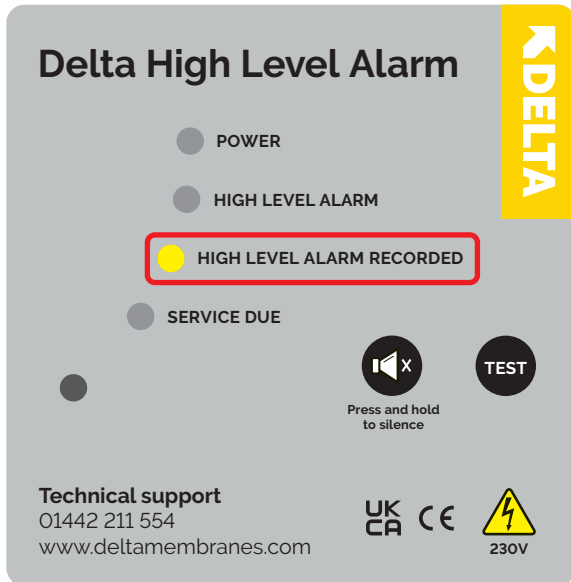

Figure 19. The high level alarm recorded indicator.

- The HLA recorded will trigger once a high level alarm condition has returned to normal.
- When a HLA is recorded the light will flash every 2 seconds.
- This will continue flashing until you hold the test button and mute button together for 10 seconds. This will reset the HLA recorded LED. After 10 seconds the sounder will beep 3 times and the HLA recorded LED will stay lit, this acknowledges the command has been successfully completed.

3.2.4 Service due (red)

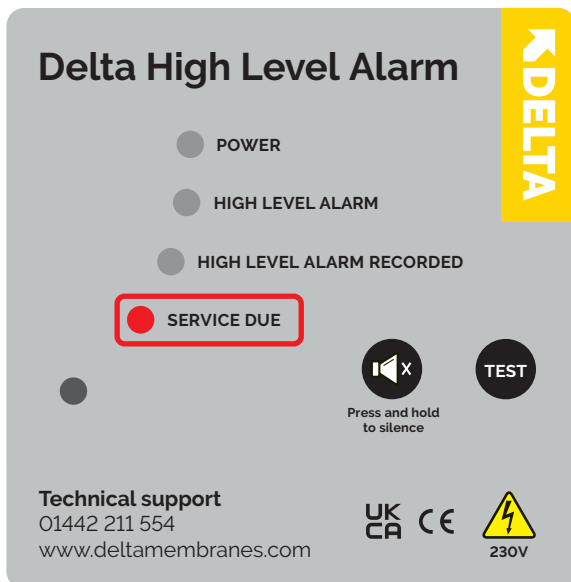

Figure 20. Service due indicator.

- Service due – if a service is due the system will flash and beep every 2 seconds.
- To mute the alarm for 7 days, see mute button, as shown in Figure 10.
- You will have the option to set the service reminder intervals. The service reminder intervals will be changeable via a series of jumper positions, as shown in Figure 8 setting the jumpers.

3.3 Sounder

The audio sounder will be activated if a test button is pressed, a high level alarm, power fail, or service reminder condition occurs. If you wish to mute the alarm, see mute button Figure 16.

4. Wiring diagrams

4.1 Mini float wiring diagram

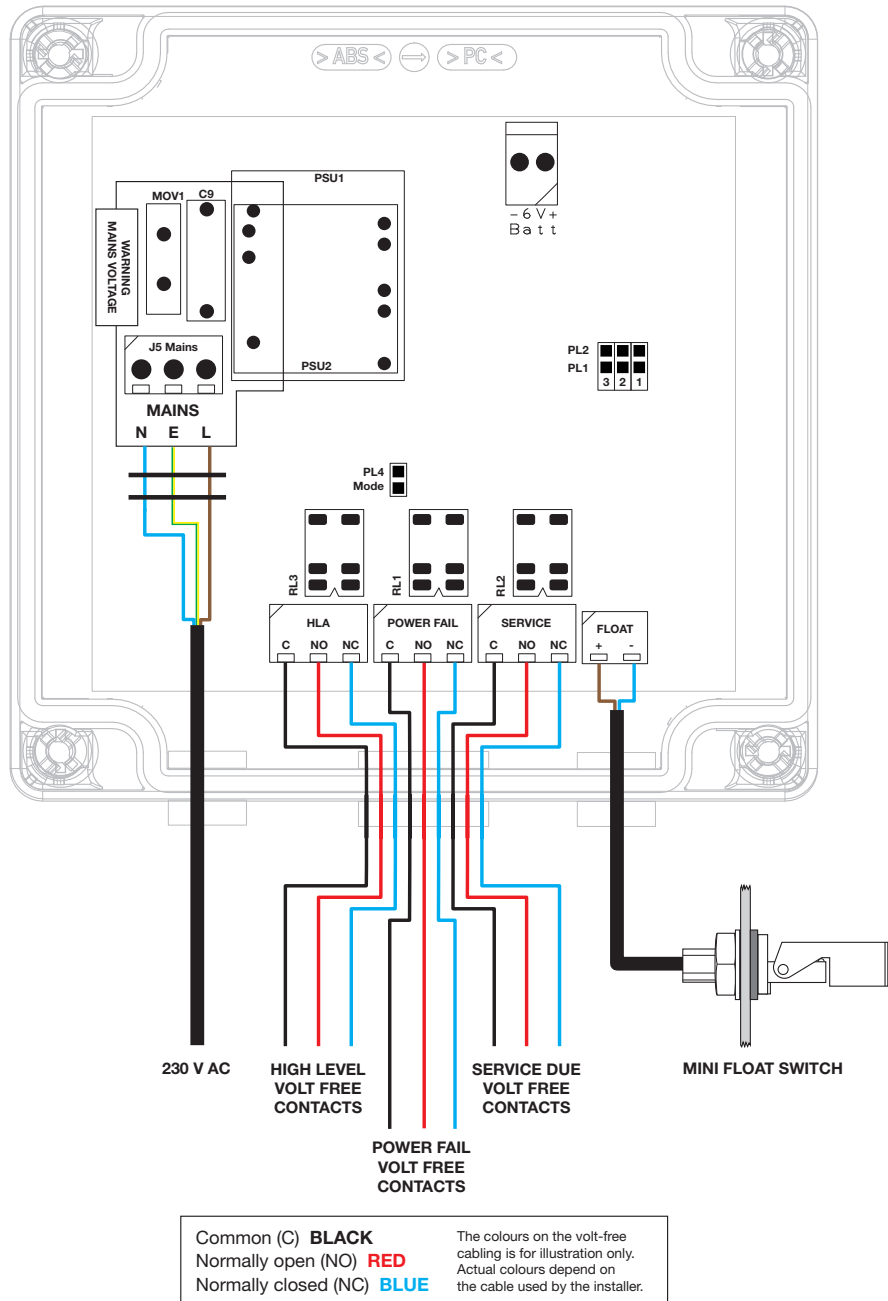

Figure 21. Mini float wiring diagram.

4.2 Sump float wiring diagram

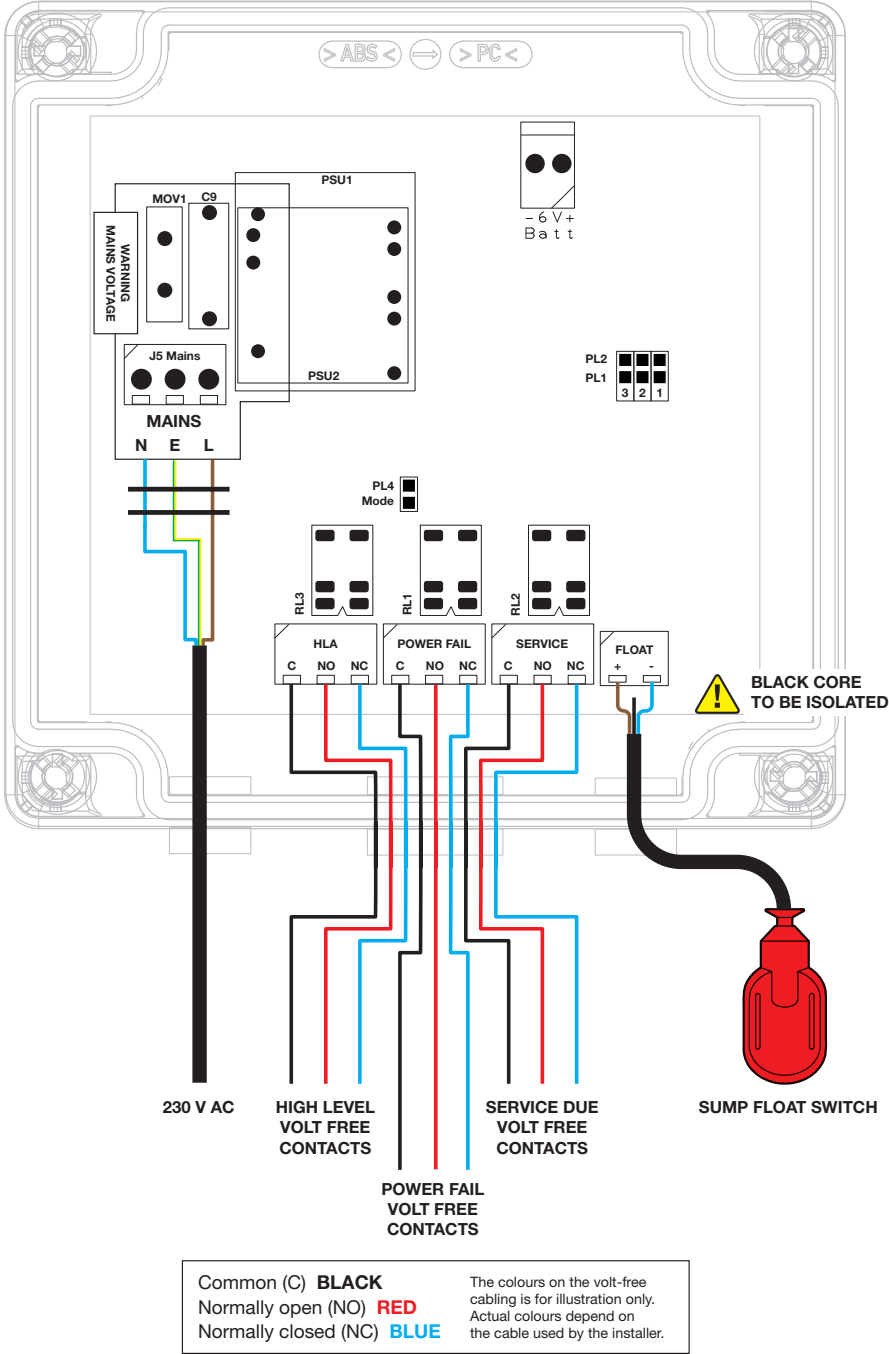

Figure 22. Sump float wiring diagram.

5. Maintenance



DANGER! DO NOT OPEN THIS UNIT IF NOT QUALIFIED TO DO SO

To reduce the risk of electric shock, do not remove cover. No user-serviceable parts inside. Refer servicing to qualified service personnel.



IMPORTANT

All maintenance works (inspections and services) **MUST** be undertaken by a technically qualified/ competent company/engineer.



DANGER!

Before carrying out any maintenance work the system **MUST** be completely disconnected from the mains power supply, and measures should be taken to prevent the system from being inadvertently switched back on.



WARNING!

When undertaking works within the chamber/sump suitable measures **MUST** to taken to ensure safe access in accordance with current safety regulations.

The product should be inspected quarterly, with the following being performed;

- Operate the test button – as shown in Section 3.1.1.
- Check HLA float switch – manually trigger the float switch to test the functionality of the high level alarm.
- Inspect all cables for signs of wear and tear.

When installed in conjunction with a pump system, please refer to the product installation and operating guidelines for pump station maintenance requirements.

In addition to the above it is important that the product undergoes a full service at a minimum frequency of once yearly (increased servicing frequency is subject to site and product specific details. Where a product is serving more than a single residential dwelling and/or there is a risk of flooding as a result of product failure the servicing frequency should be increased accordingly).

To arrange a service please contact Delta Membranes on 01992 523 523 between 8am and 5pm, Monday to Friday or by email at info@deltamembranes.com for more information.

Delta Membrane Systems Ltd recommends all pumps, alarms and associated products are serviced by a Delta Registered Pump Service Provider.

Please replace the internal battery every 2 years.

6. Fault finding

Problem	Cause	Solution
High Level Alarm is constantly sounding	Damaged float cable	Repair float cable
High Level Alarm is constantly sounding	Faulty float switch	Replace float switch
High Level Alarm is constantly sounding	PL4 jumper in incorrect position	Remove jumper from PL4 to enable normally closed contact on the HLA float switch connection
High Level Alarm is constantly sounding	Pump has failed and station is at high level	Contact Delta Membranes on 01992 523 523 for further assistance
High Level Alarm is sounding before the pump activates	Float level set incorrectly	Raise the height of the HLA float switch so it activates higher than the activation point of the primary pump
No volt free output to external devices	Signal cable is connected to the incorrect NO/NC contact	Move signal cable to the correct contact
No power LED lit	No mains power to the system and the battery not connected	Check the mains power supply in from the distribution board and connect the 6V battery

If you continue to experience problems, please contact Delta Membranes on 01992 523 523 between 8am and 5pm, Monday to Friday or by email at info@deltamembranes.com for more information.

7. Ancillaries

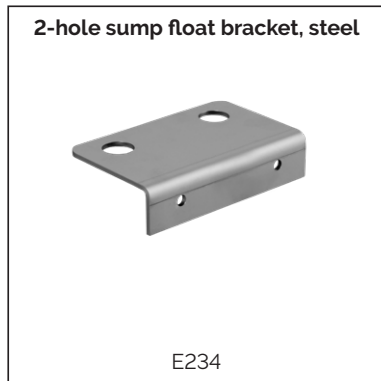
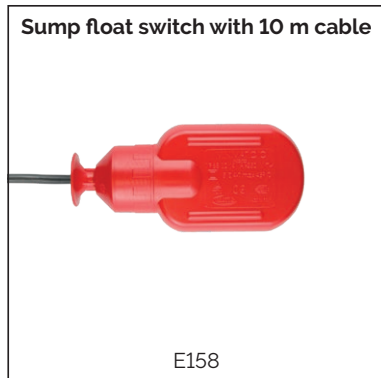
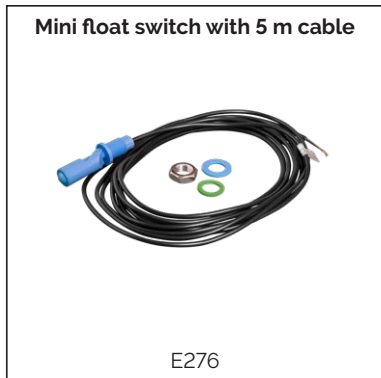

8. Declarations

8.1 The European Union Waste Electrical and Electronic Regulations 2013

This PCB assembly is classified as Electrical or Electronic equipment and should not be disposed of in normal domestic or commercial waste. The mandatory crossed out wheeled bin symbol (see above) on the product indicates that the product shall not be mixed or disposed of in household or commercial waste. Under the WEEE Directive, the equipment should be recycled using the best possible techniques to minimise environmental impact and avoid unnecessary landfill.

For further information, visit <http://www.legislation.gov.uk/ukxi/2013/3113/contents/made>

8.2 UKCA and CE approved

The product complies with the relevant sections of:

- The Low Voltage Directive, EN61010:2010, and
- The EMC Directive EN55014:2006, A1 and EN55014-2:201513.



9. Warranty



9.1 Standard 12-month component warranty

The Delta HLA is offered with a 12-month component warranty from the date of invoice.

Standard Delta Membrane Systems Limited conditions apply.

This warranty does not cover defects caused by incorrect installation, installation/installer error, abnormal working conditions, misuse, or neglect.

Any defects or malfunctions should be reported to Delta Membrane Systems Limited within of seven days when defect becomes apparent. All broken components should be returned to Delta Membrane Systems Limited at customer cost.

To make a Warranty Claim, please email pumps@deltamembranes.com. Forms are available from www.deltamembranes.com.

In no event shall Delta Membrane Systems Limited be liable for any consequential damage, penalties, loss, or expenses howsoever arising, out of or in connection with incorrect installations or misuse, including, without limitation, direct or indirect loss, consequential loss or damage, loss of profit or goodwill, loss arising from any errors or omissions in the pump chamber as a result of, incorrect installation, installation/installer error, abnormal working conditions, misuse, or neglect.

Delta Membrane Systems Limited shall not accept liability if the product fails due to being incorrectly specified by any third parties not employed by Delta Membrane Systems Limited.

9.2 Warranty from date of commissioning

When the Delta HLA is commissioned by a Delta Registered Pump Service Provider, the 12-month warranty period shall start from date of commissioning, provided:

- all services and associated systems are ready to enable commissioning to take place;
- the Delta HLA is commissioned within 12 months from the date of invoice;
- the Delta HLA is commissioned by a Delta Registered Pump Service Provider;
- the Delta Registered Pump Service Provider has logged Commissioning details of the Delta HLA with Delta Membrane Systems Limited;
- the Delta HLA is serviced by a Delta Registered Pump Service Provider with a minimum of a yearly Service (within 12 months from the date of commissioning/last service) depending on site specifications.

10. Mounting plate template

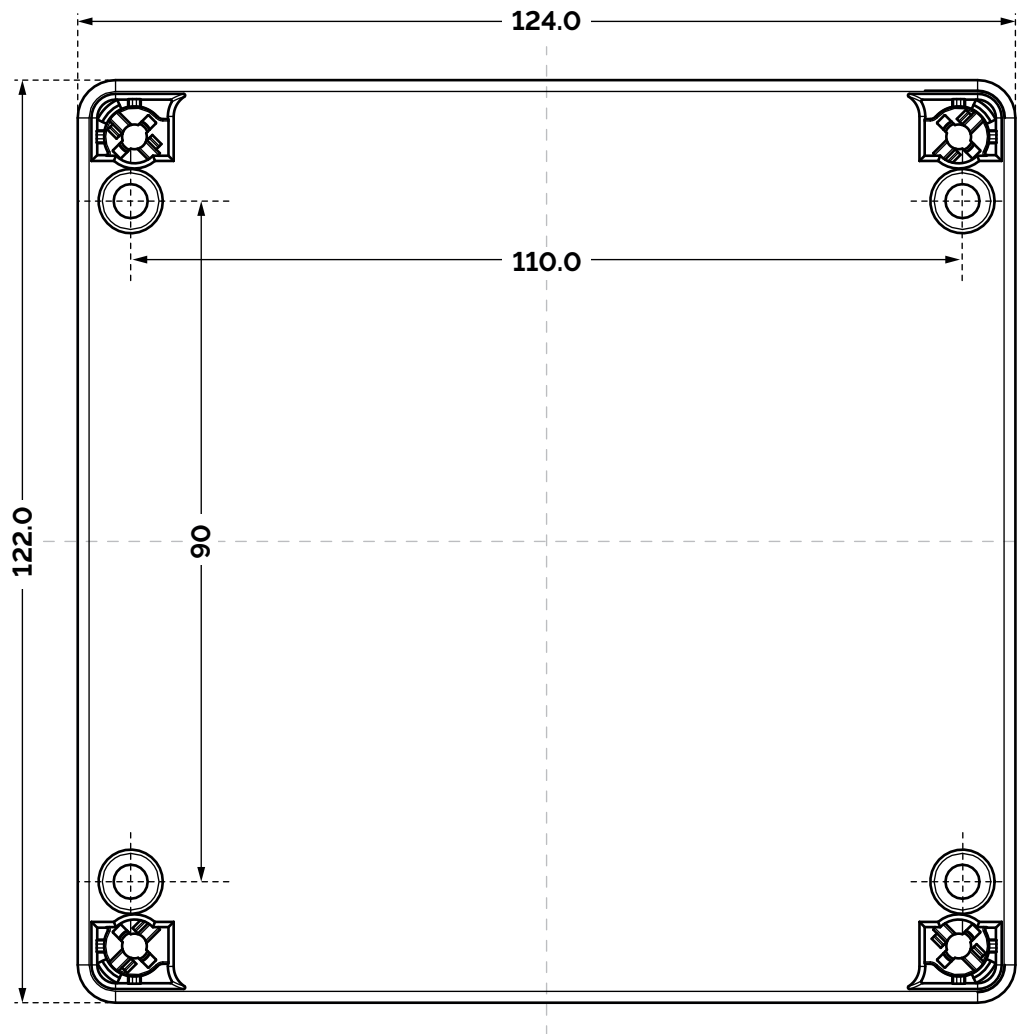

Figure 23. Mounting template.

If using a printed copy as a drilling guide, print out at 100% enlargement, and check the dimensions of the printed copy before drilling.

11. Commissioning details

Property address	Commissioning engineers

Customer contact details	
Contact name	
Contact telephone	

Installation details	
Equipment installed	
Delta Registered Pump Service Provider	
Date of commissioning	
Commissioning engineer	
Signature of engineer	

Servicing plans

Sump pumps must be maintained. We recommend a qualified engineer examines and services equipment every year. Pumps running frequently due to higher water table, water drainage, or weather conditions should be examined more frequently, we recommend every 6 months. Sump pumps, being mechanical devices, may fail if not maintained which could lead to a flooded basement and costly repairs. Regular servicing of sump pumps will increase efficiency and extend the life of the pump. All Delta Membrane pump systems can be maintained and serviced by our recommended service companies or installing contractor.

Commissioning

All sump pumps require commissioning. Commissioning provides peace of mind, knowing that the system is installed correctly and in compliance with warranty conditions. All Delta Membrane pump systems can be commissioned by our recommended service companies or installing contractor.

Delta Membrane Systems Ltd, Delta House, Merlin Way, North Weald, Epping, Essex, CM16 6HR.

01992 523 523 info@deltamembranes.com www.deltamembranes.com

 [deltamembranes](https://www.facebook.com/deltamembranes)  [deltamembranes](https://twitter.com/deltamembranes)  [delta-membrane-systems-ltd](https://www.linkedin.com/company/delta-membrane-systems-ltd)  [deltamembranesystems](https://www.youtube.com/deltamembranesystems)