

GVL 8408-M Troubleshooting Guide

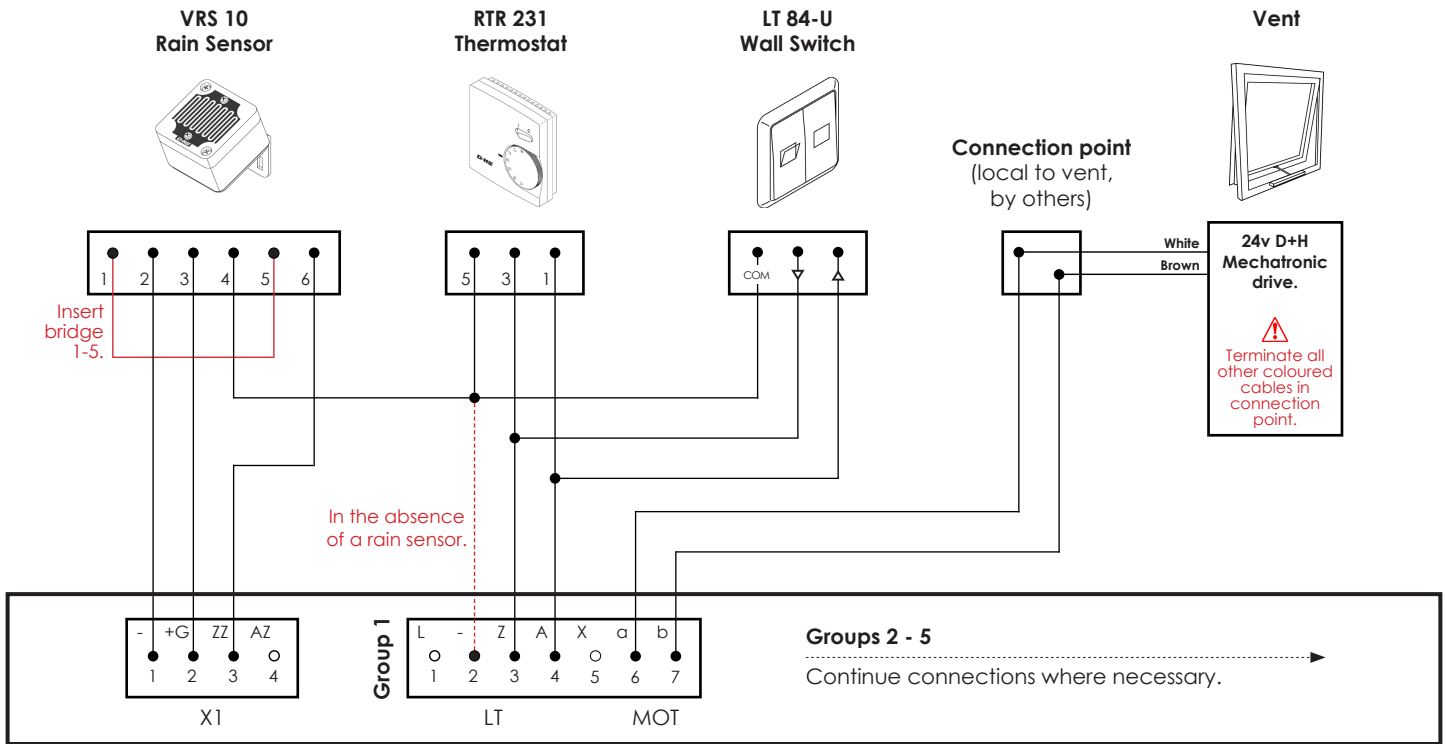

Operational configuration / faults

Rain Sensor:

- Ensure bridge is installed in rain sensor across terminals 1 and 5.
- Connect the common (-) for thermostat or wall switch through terminal 4 on rain sensor, not directly from the control panel when a rain sensor is in the system.
- Ensure DIP-Switch 3 is 'ON' for each group to be operated by the rain sensor.
- Rain sensor will provide a close signal for up to 10 minutes after rain has stopped or the sensor has dried completely.

Thermostat:

- The thermostat will only provide an open or close signal when turned on (I = on, 0 = off).
- If there is no rain sensor in the system the common (-) for thermostat is connected directly into no.2 (-) on the LT terminal.
- Thermostat will operate on temperature readings 1° above or below the set-point temperature. E.g. Set-point temperature 20°, open at 21°, close at 19°.

Wall Switch:

- The wall switch will only provide a open or close signal when the thermostat is turned off (I = on, 0 = off).
- If there is no rain sensor in the system the common (-) for wall switch is connected directly into no.2 (-) on the LT terminal.
- Wall switch operation (latching or non-latching) is configurable on S1-S5 DIP-Switches numbers 1 and 2. See installation instructions.

Drive:

- Check MOT terminal connections in the control panel and local connection point.
- Test power supply from terminals A and B in control panel, minimum of 24v DC should be present on operation.
- If voltage is present on operation and connections are correct, the issue is with the drive(s) and not the controls. See drive instructions for assistance.

DIP-Switches:

- For operational set-up (including automatic override functions and one-touch operation) see DIP-Switch information on the GVL 8408-M control panel installation instructions.