



Cyclepods

Transforming bike storage



TRANSFORMING BIKE STORAGE

WWW.CYCLEPODS.CO.UK - T:01959 546 046 - INFO@CYCLEPODS.CO.UK



Cyclepods is all about bikes and cyclists. Our total focus is on helping cyclists feel more confident that their bikes are being held securely, and safely, in locations which fit with their travel and commuting plans.

Year on year since inception we have developed, designed & manufactured innovative cycle storage solutions that are designed to save 50% less space than conventional stands whilst preventing overcrowding and damage to bikes and ensuring maximum security. Since 2005 we have installed over 100,000 bike spaces across the UK and that number is increasing every day!

From home bike storage solutions to high volume Cycle Hubs, our product range includes traditional stands and shelters, lockers, two-tier storage and our innovative, space-saving solutions made from 100% recycled or recyclable materials. We believe that the use of recycled materials should not compromise quality and that bike parking should encourage cycling and a healthier way of life.

Available in a wide range of assorted colours and finishes, our products lend themselves to different environments; bike parking no longer has to be hidden as an eyesore. In fact, we have gone a stage further and provided advertising and branding opportunities on our products.

More recently we have developed and produced state-of-the-art cycling infrastructure and technology such as cycle lane separators, cycle counters, access control for hubs, bike detection, public bike pumps and repair stands and bike hire systems.

Cyclepods not only design products; we also design projects, often large and complex. We work with our clients on design, planning permission and stakeholder engagement.

With our in-house design team, project management and nationwide installation service, we work to each client's individual requirements to ensure best-fit solutions.

CYCLEPOD

The Cyclepod is our flag ship cycle storage product which makes a real impact. The eye catching design secures 8 bikes in a two meter diameter.

The Cyclepod is an ideal bike storage solution for secure or semi secure locations where space and aesthetics are particularly important.

The Cyclepods can be used together with the Spacepod to go around corners and to form a "Cyclepod island" which holds more than 8 bikes.

When combined with the canopy, it creates a fully sheltered cycle store.



Product Name: MDPE Cyclepod.

Panel Material: Medium density polyethylene (MDPE), Black version is standard and is recycled and recyclable. All other colour versions are just recyclable.

Panel Thickness: 7-9mm**. Outer lower rim 20mm high. 60mm channel/track to cater for 99% of all standard European tyre width's. Rain water holes in base of every track.

Panel Finish: Dimpled effect with varying colour range

Panel Weight: 20kg each. Overall weight 150KG (with Securing arms). 4 panels per MDPE Cyclepod.

Securing Arms Material: 25mm diameter 2.5mm thickness recycled grade Stainless Steel tube or 20mm Galvanised Solid rod (standard). Metal reinforcement plates added to arms.

Number of securing arms: 4 Upper arms and 8 lower arms. The securing arms provide two individual locking points per space.

Top Plate Material: 5mm Stainless steel or galvanised steel.

Fixing Method for Securing Arms: Nyloc nut and Washer. All housed internally so no visible fixings.

Fixings Material: All standard Cyclepod fixings are Stainless steel. Ground anchors are nickel plated.

Ground Fixings Required: 16mm outer diameter shield anchor bolts drilled to a depth of 100mm max. 2 fixing bolts required per panel. Fixing will vary due to substrate.

Ground Type Required: Solid level base required. Concrete, large slabs etc.

Product Code: CYC001.

Colour Options: Black (Recyclable) Red, Yellow, Royal Blue, Light Blue, Dark Green, Light Green, Grey and Stone effect available.

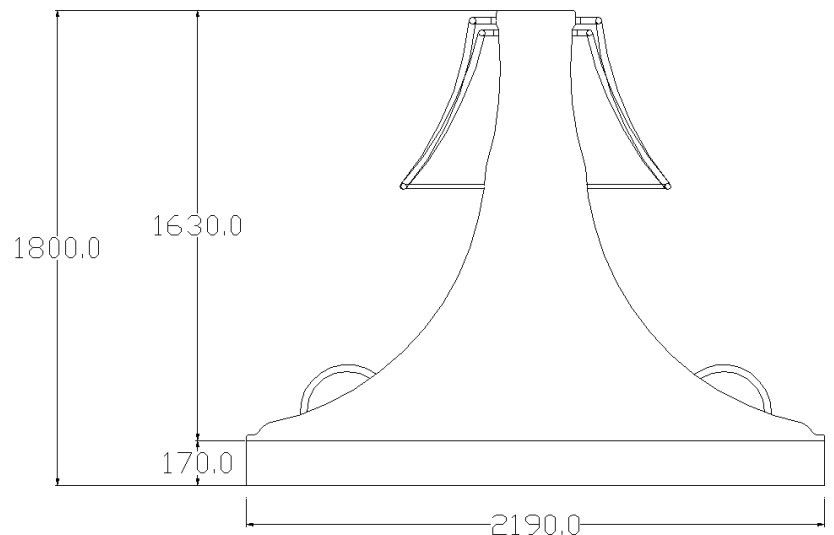
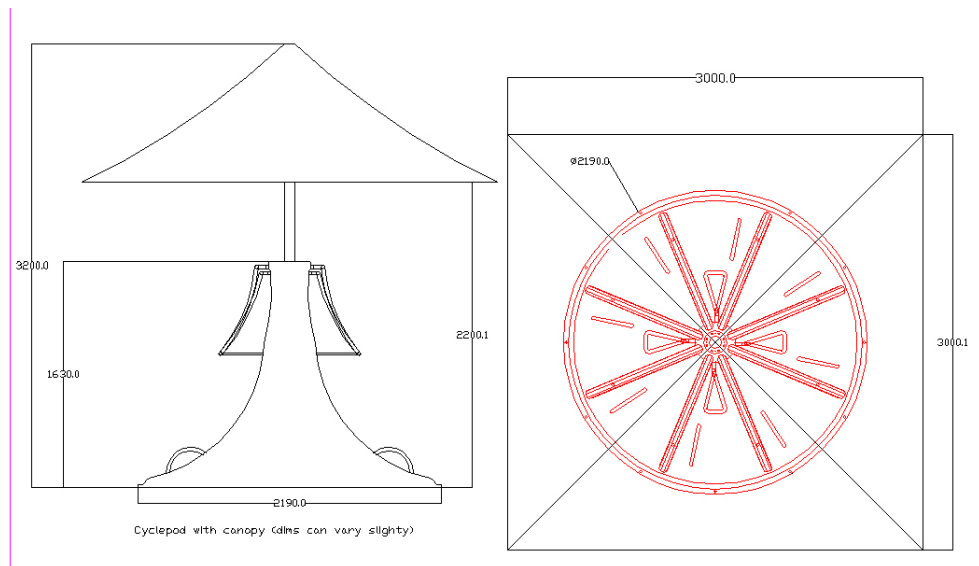
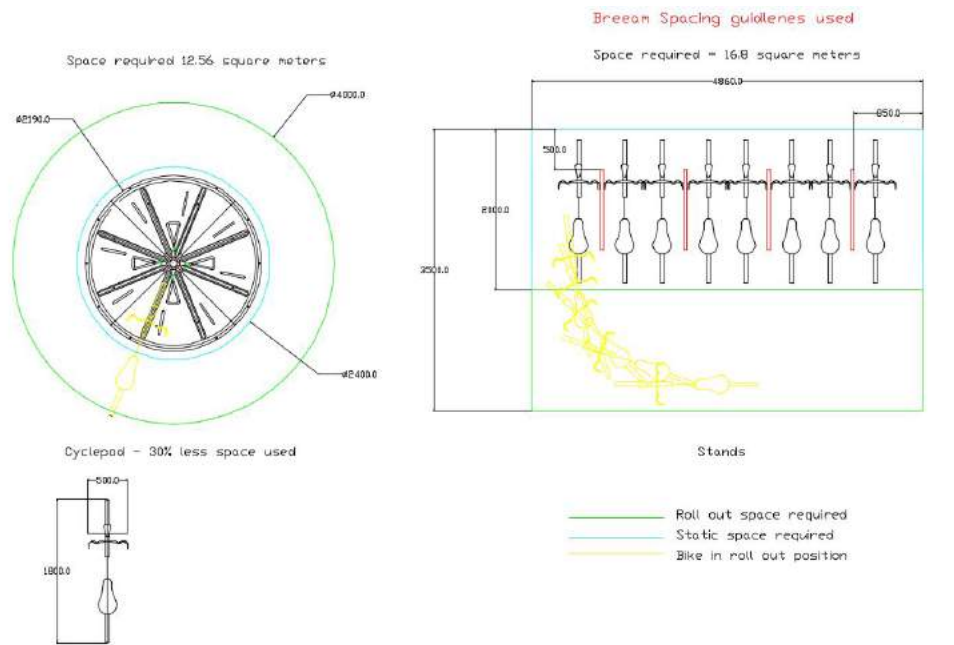

SPACEPOD

The Spacepod is a highly configurable product which uses up to 50% less space than traditional bike storage.

The Spacepod offers 2 secure separate locking points and is an ideal solution where space is at a premium or where only wall space is available.



SPACEPOD SPACE SAVINGS

Product Name: MDPE Spacepod Panel.

Panel Material: Medium density polyethylene (MDPE), Black version is standard and is recycled and recyclable. All other colour versions are just recyclable.

Panel Thickness: 7-9mm**. Outer lower rim 20mm high. 60mm channel/track to cater for 99% of all standard European tyre width's. Rain water holes in base of every track.

Panel Finish: Dimpled effect with varying colour range.

Panel Weight: 15kg each.

Securing Arms Material: 25mm diameter 2.5mm thickness recycled grade Stainless Steel tube or 20mm Galvanised Solid rod (standard). Metal reinforcement plates added to arms.

Number of securing arms: 1 Upper arm and 1 lower arm. The securing arms provide the cyclist two individual locking points for both front wheel and frame plus back wheel and frame.

Top Plate Material: 5mm Stainless steel or galvanised steel.

Fixing Method for Securing Arms: Nyloc nut and Washer. All housed internally so no visible fixings.

Fixings Material: All standard Cyclepod fixings are Stainless steel. Ground anchors are nickel plated.

Ground Fixings Required: 16mm outer diameter shield anchor bolts drilled to a depth of 100mm max. 2 fixing bolts required per panel.

Ground Type Required: Solid level base required. Concrete, large slabs etc.

Product Code: CYC001.

Colour Options: Black (Recyclable) Red, Yellow, Royal Blue, Light Blue, Dark Green, Light Green, Grey and Stone effect available.

Breezeam Spacing guidelines used

Space required = 16.8 square meters

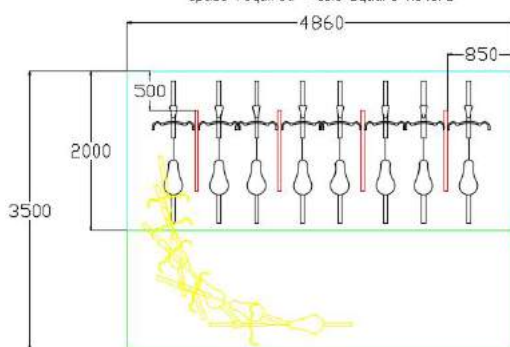

Space required = 8.6 square meters

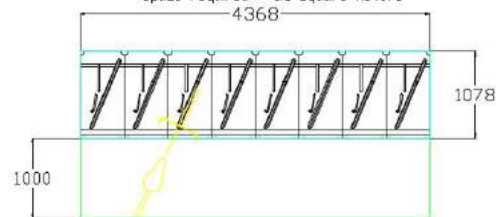

Spacepod = 45% less space used

Stands

Roll out space required
Static space required
Bike in roll out position

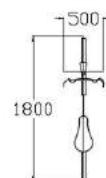

SPACEPOD DIMENSIONS

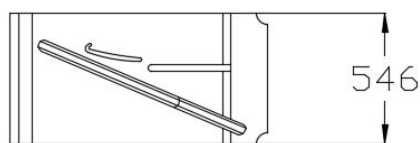
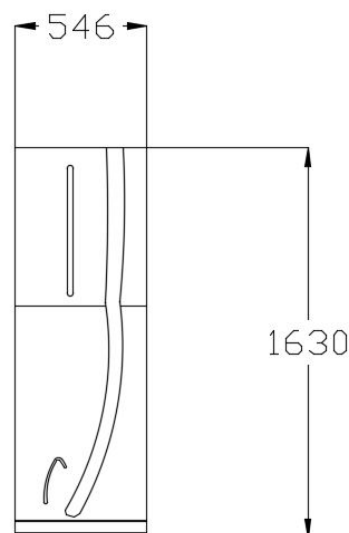
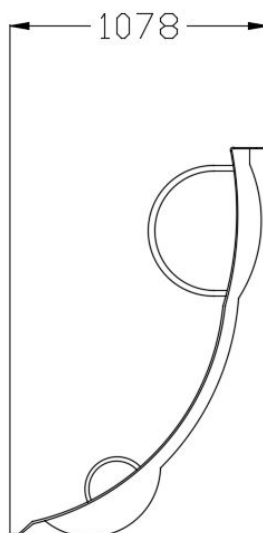

SPACEPOD LAYOUT EXAMPLES

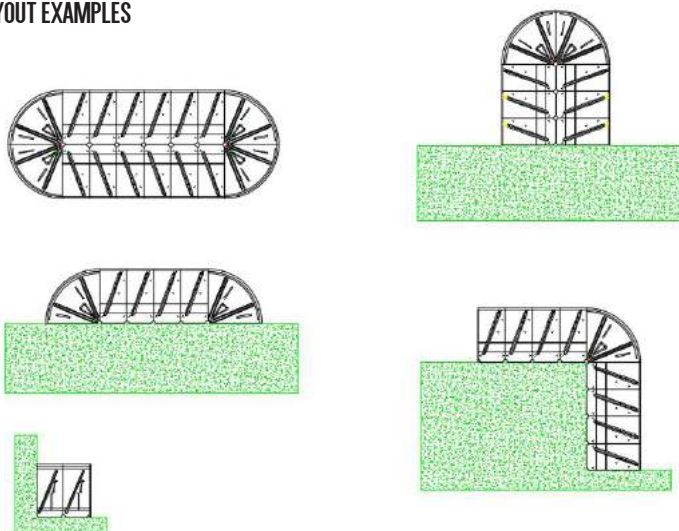

STREETPOD

The Streetpod is our latest revolutionary cycle storage design! This highly secure and stylish product offers maximum bike protection for public location and open spaces, where bike security is a concern.

The Streetpod is Secured by Design accredited and UK police recommended, it is also the only free-standing cycle parking solution in the UK which has achieved Sold Secure Silver certification.

The front wheel is housed within the security shield which prohibits it from being removed.

The Streetpod has the ability to secure the bike frame and both wheels with a single lock. This highly configurable design can also accommodate advertising and sponsorship.



Product Name: Streetpod—SBD

Panel Material: Medium density polyethylene (MDPE), Black version is recycled and recyclable, where as colour versions are just recyclable.

Wall Thickness: 7-9 mm. 65mm channel/ track width to cater for 99% of all standard European tyre width's.

Finish: Dimpled effect. Standard colour black, other colours available at additional cost.

Product Weight: 20kg each.

Securing loop: Galvanised Steel as standard, Stainless steel option available.

Securing loop thickness: 50 mm diameter, with 3.2mm thickness . 20mm solid securing bar.

Fixing Method for loop Arms: Fixed to floor using ground anchors/resin.

Fixings Material: All standard Streetpod fixings are Galvanised/Stainless steel. Ground anchors are nickel plated.

Ground Fixings Required: 3 types: 16mm outer diameter shield anchor bolts drilled to a depth of 100mm max . Self using M14 Sheer off nuts and resin. 5 fixing bolt required per Streetpod.

Ground Type Required: Solid level base required. Concrete, large slabs with minimum 50mm thickness.

Internal fixings: Shear off nuts + Loc tight to be used on all internal fixings.

Product Code: STREET001

Colour Options: Standard in Black (Recyclable) Red, Yellow, Royal Blue, Light Blue, Dark Green, Light Green, Grey, Stone effect and multicolour available.

Various shelter options available for all products.

STREETPOD SPACE SAVINGS

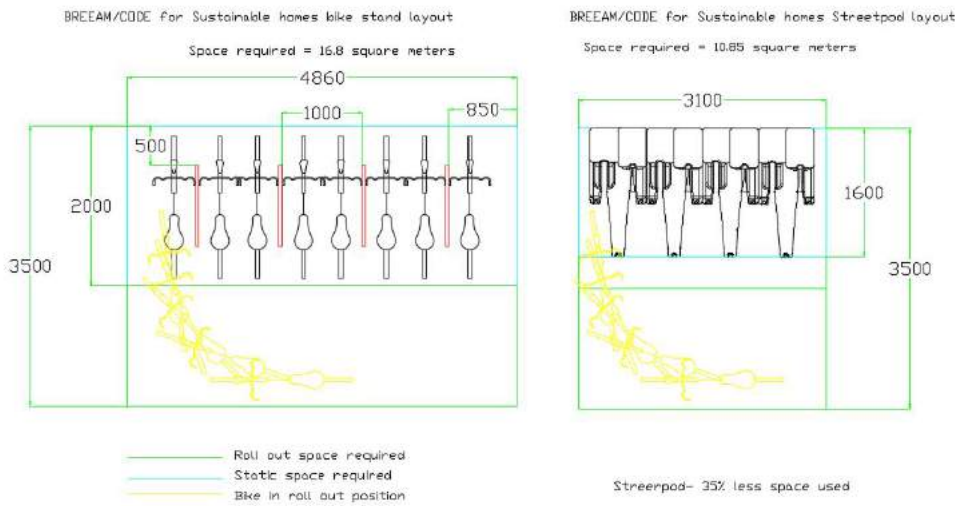

STREETPOD DIMENSIONS

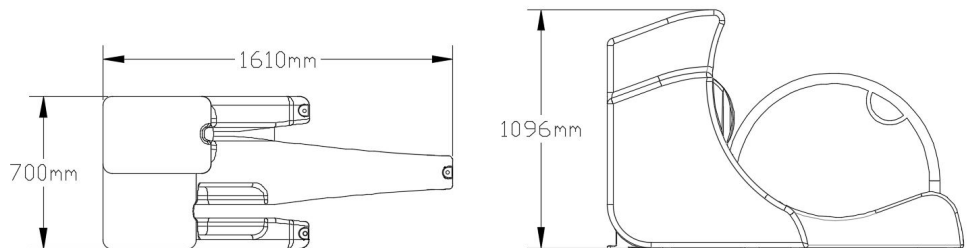

STREETPOD 3D VIEW

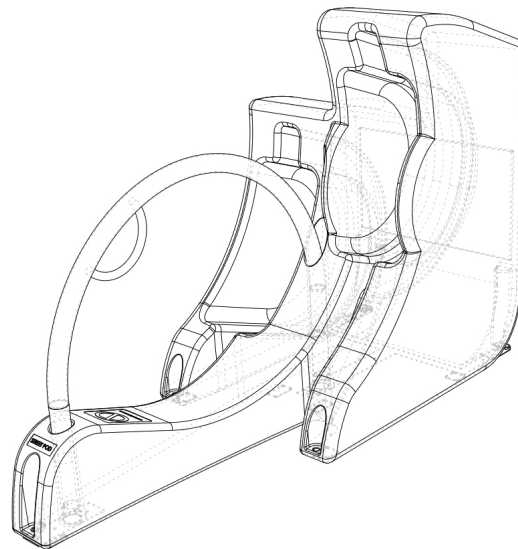

HOW TO LOCK YOUR BIKE TO THE STREETPOD:

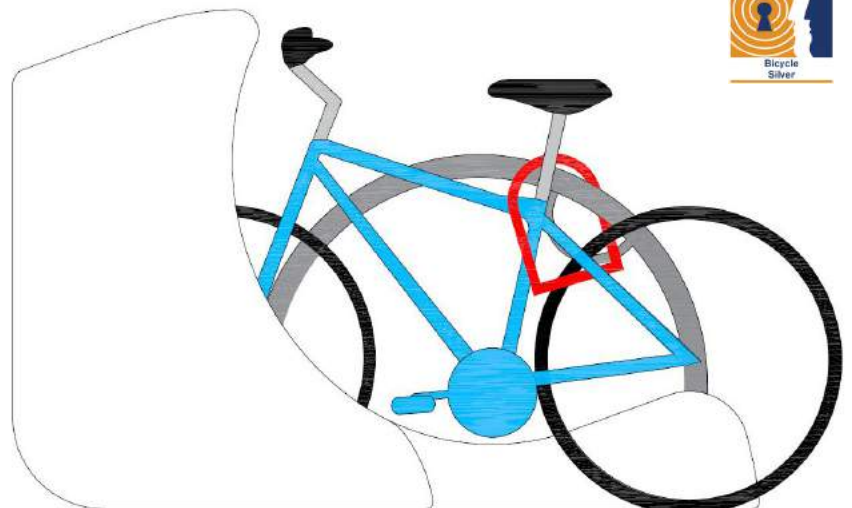

TWO TIER STORAGE - WHATS THE DIFFERENCE?

FREESTANDING - NO GROUNDWORKS NECESSARY

Cyclepods provide two types of two-tier storage systems: the Easylift Premium and the CapaCITY, but what's the difference? They both are:

- **STYLISH DESIGN**
- **FREESTANDING - NO GROUNDWORKS NECESSARY**
- **EXCELLENT VALUE FOR MONEY**
- **EXCEPTIONALLY USER-FRIENDLY AND SAFE**
- **MODULAR SYSTEM; SPACES CAN BE ADDED**
- **SUSTAINABLE, RELIABLE AND LOW-MAINTENANCE**

EASYLIFT PREMIUM

- **EXTRUDED ALUMINIUM AND GALVANISED STEEL CONSTRUCTION**
- **PREMIUM PRODUCT - ULTIMATE IN USER FRIENDLY DESIGN**
- **POWDER COATING AVAILABLE ON THE LEGS, FRAME AND LOWER RACKS.**
- **NOISE DAMPENING**

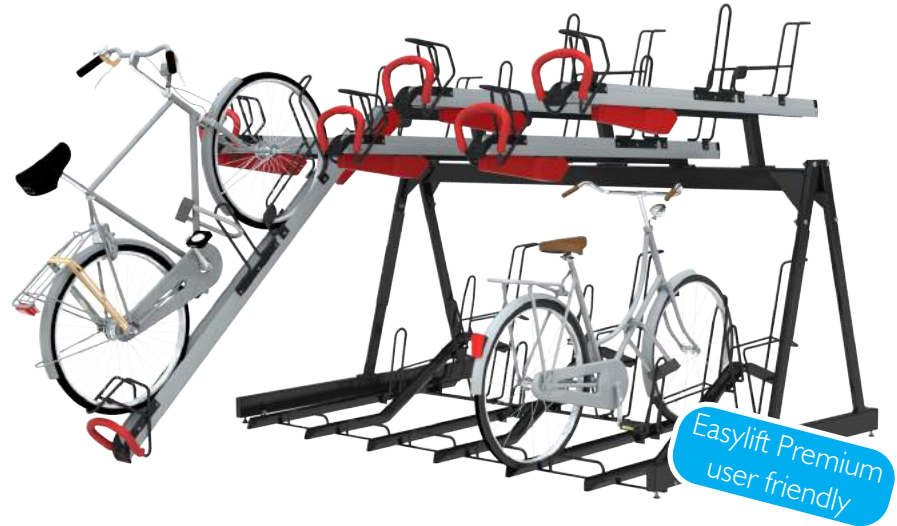

CAPACITY

- **GALVANISED STEEL CONSTRUCTION**
- **BUDGET FRIENDLY PRODUCT**
- **POWDER COATING AVAILABLE ON THE UPPER RACKS, LEGS, FRAME AND LOWER RACKS.**
- **AVAILABLE IN THE SAME CONFIGURATIONS AS THE EASYLIFT PREMIUM**

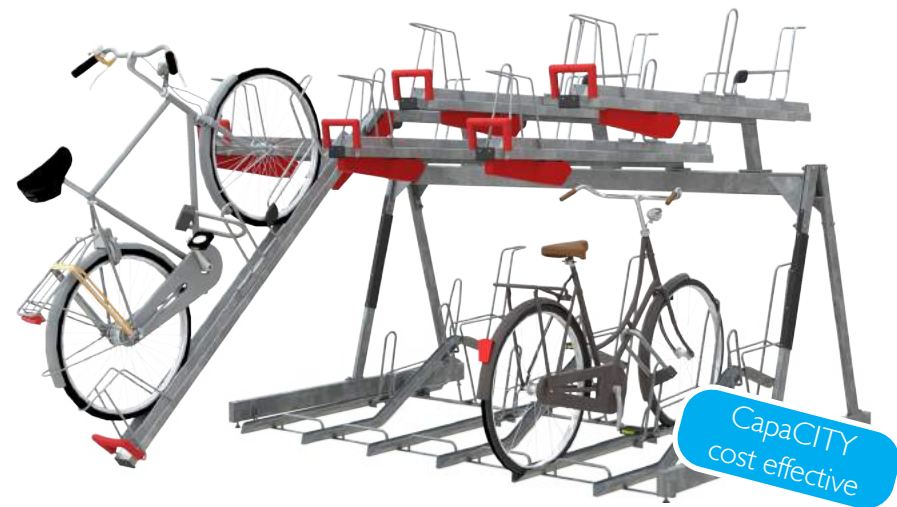

Features	Easylift Premium	CapaCITY
User friendly	★★★★★	★★★★☆
Gas assisted	✓	✓
Ergonomically designed, non slip hand grips	✓	✓
3 individual locking points per space	✓	✓
375mm centre to centre distance	✓	✓
Low loading height	31cm	37cm
No groundworks required	✓	✓
Extendable to accommodate any number of bikes	✓	✓
Easy to move and install in another location	✓	✓
Controlled hands-free descent	✓	
Noise dampening	✓	

Product Name: Easylift Premium Two Tier.

Depth of unit: 1900mm.

Minimum manoeuvring space: 2100mm.

Track material: Aluminium.

Galvanised supports and cross beams:
Finished to BS ENISO11461.

Handle Material: Red Polymer handle with
steel support.

Lowering Mechanism: Gas assisted.

Centre to centre per bike: 375mm (standard)
- 400mm - 500mm.

Surface mounted: Free standing, no bolting
down into ground required.

Configurations:

Single Sided: 4-8-12-16.

Double Sided: 8-16-24-32.

Units can be bolted onto each other to form
a continuous line to desired length.

Modular construction: Can be extended
upon.

Security: 3 individual locking points per rack.

Warranty required for Two tier: 5 years.

Overall Clearance: Minimum Height
required: 2600mm.

Product Code: ELIFT01 (alu).

Frame Finish Options: Galvanised,
Galvanised and Powder Coated.

FIETSPARKEUR achieved in 400mm centres
version.

Various shelter options available for all
products.

SINGLE SIDED CONFIGURATIONS

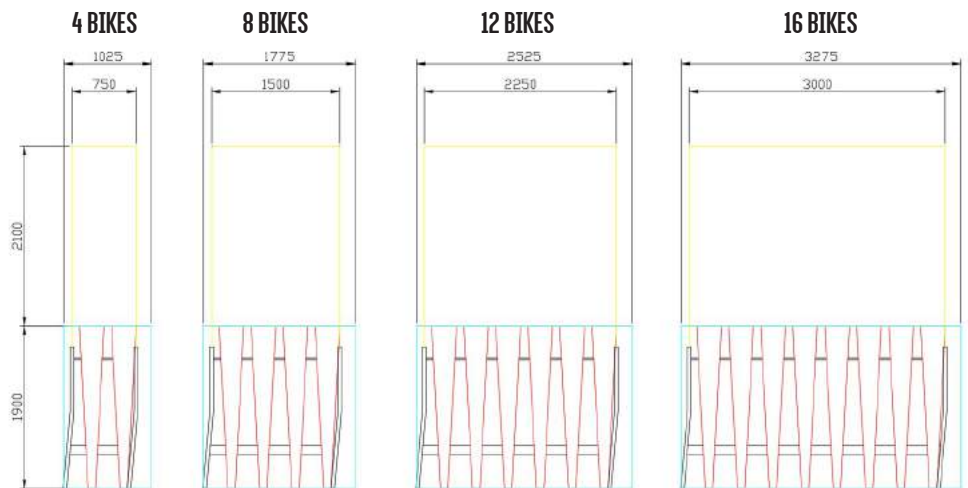

DOUBLE SIDED CONFIGURATIONS

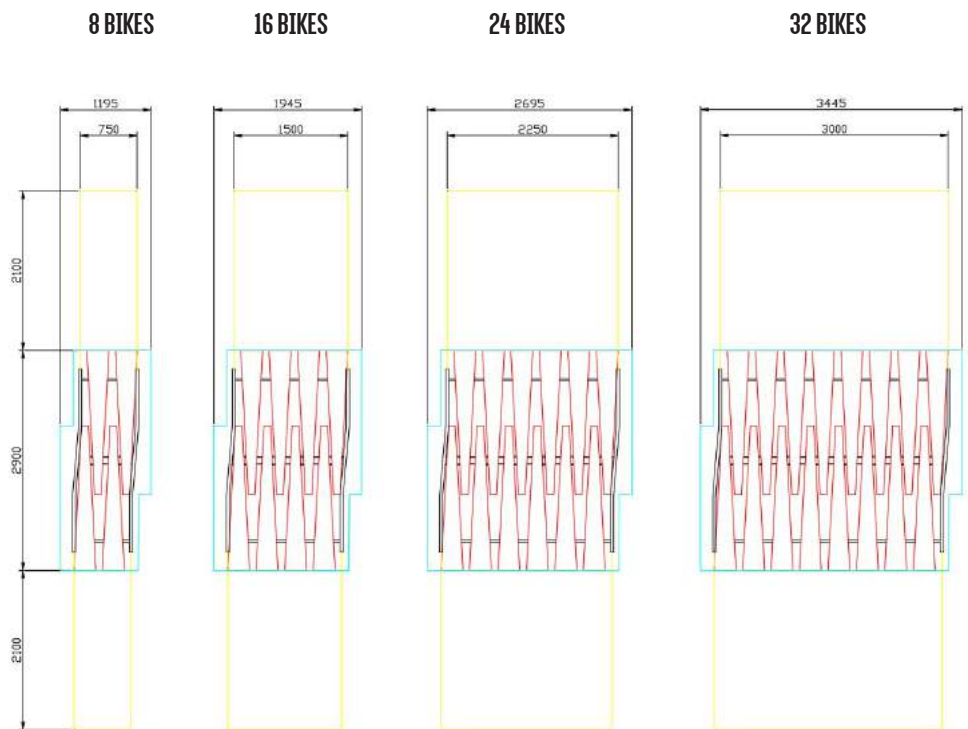

SIDE ELEVATION

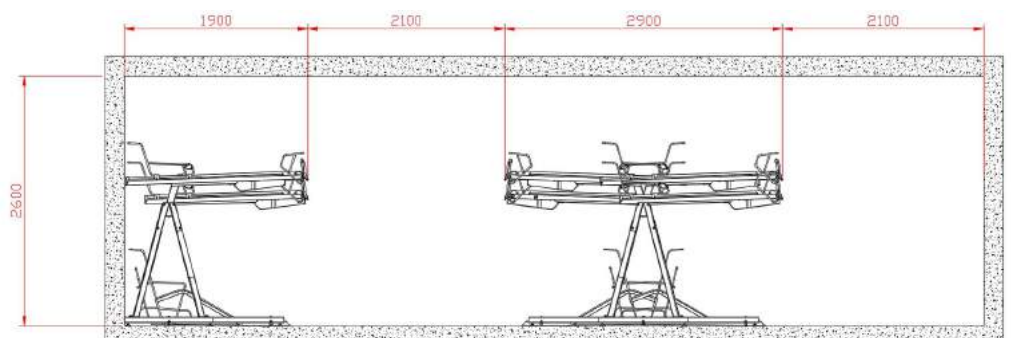

EASYLIFT PREMIUM

The Easylift Premium is a highly convenient gas assist two-level bicycle parking system. The lifting system ensures that a bicycle can be parked on the top level effortlessly.

Key Benefits

- The most successful two tier cycle parking system with 65,000 installed at Dutch stations alone over last 4 years.
- Eight thousand spaces installed in UK over last 4 years
- Easy to use:
 - a. Light aluminium upper arm
 - b. Upper arm on casters for easy glide action
 - c. Upper arm reaches to the floor for ease of loading bike
- European manufacture for quality assurance
- Welded and bolted construction. Security bolts give additional security
- Gas assist action:
 - i. Dampers stop upper arm from falling down uncontrolled
 - ii. Lifts loaded upper arm with little effort



CAPACITY TWO TIER

The CapaCITY two tier is a highly convenient gas assist two-level bicycle parking system. The lifting system ensures that a bicycle can be parked on the top level effortlessly.

Key Benefits:

Easy to use:

Galvanised steel upper arm

Upper arm on casters for easy glide action.

Upper arm reaches to the floor for ease of loading bike.

European manufacture for quality assurance.

Welded and bolted construction.
Security bolts give additional security.

Gas assist action:

Dampers stop upper arm from falling down uncontrolled.

Lifts loaded upper arm with little effort.



CYCLE SHELTER DESIGNS

We have designed a wide range of both single-tier and two tier parking shelters that are robust, stylish and yet functional. Cabling can be run up the legs of the shelters thus avoiding the need for unsightly trunking. Some of our shelter roofs are designed in such a way that algae, tree sap or rubbish can't be seen from below and thus avoiding service quality fails or high level maintenance. Sheltered bike racks can be securely enclosed with fencing and lockable gates.

These are our most popular shelters, but we offer a wide range and can create bespoke items.

CANTERBURY SHELTER



HARROGATE SHELTER



MANCHESTER SHELTER



CAMBRIDGE SHELTER



TWO TIER CYCLE SHELTER DESIGNS

Our two tier cycle shelters are designed to fit our Easylift and CapaCITY two tier systems or retro-fitted to existing two tier systems, they allow extra room for a second level of bikes while providing full coverage. As with our single tier shelters, cabling can be run up the legs of shelters and additional options such as drainage and lighting can also be installed.

These are our most popular two tier shelters, but we offer a wide range and can create bespoke items.

BRIGHTON SHELTER



KINGSTON SHELTER



LOCKERPOD

Lockerpods offer safety and security for your bike. If you're fed up with losing bits from your bike, getting a wet seat and dragging your helmet and bag around with you... *Lockerpods* are the answer!

Lockerpods features double security. The door hasps are made of protected stainless steel tabs, drilled to accept padlocks. Internally it is designed so that a ground anchor can be installed to accept a D Lock or chain for additional security.



LOCKERPOD+

The Lockerpod+ is the ideal bike parking locker solution for your home or business! Securing up to 4 bikes in a stylish design and manufactured in 100% recyclable material. The Lockerpod+ will keep your bikes secure and dry using a lot less space than your average shed!

The Lockerpod+ and +SS are the only Sold Secure Approved lockers in the UK!

The Lockerpod+ has a 3-point locking system and key operated door so you don't need to worry about padlocks! You can have the unit "free-standing" on grass/concrete etc or you may choose to bolt through the inside base onto a hard standing surface for extra security.



MINIPOD

The Minipod is a unique product designed to get children cycling. The Minipod is an innovative product which allows 8 bikes and 8 scooters to be secured.

Available in a range of different colours, the Minipod is ideal for primary schools encouraging cycling and the children love them!

There are now over 2500 Minipods installed at schools across the UK.

They can be placed on their own, in halves against a wall or on portable bases and mats.



Product Name: Minipod Quadrant

Material: 100% Recyclable MDPE plastic.
100% Recyclable and 100% Recycled MDPE plastic (black).

Our Scooterpods have been used successfully within BREEAM schemes throughout the UK.

Panel Thickness: 14mm. Outer lower rim 20mm high. 60mm channel/track width to cater for 99% of all standard European tyre widths.

Panel Finish: Dimpled effect finish.

Panel Weight: 5kg each. Overall weight 75Kg

Securing Arms Material: Recycled Grade Stainless Steel.

Number of securing arms: 8 Upper arms (for bikes), 8 Scooter securing arms.

Securing Arms thickness: 2mm thick walled tube. Scooter securing thickness 5mm.

Top Plate Material: 5mm Stainless steel.

Fixing Method for Securing Arms: Nyloc nut and Washer. All housed internally so no visible fixings.

Fixings Material: All standard Cyclepod fixings are Stainless steel. Ground anchors are nickel plated.

Ground Fixings Required: 16mm outer diameter shield anchor bolts drilled to a depth of 100mm max. 2 fixing bolt required per quadrant.

Ground Type Required: Solid level base required. Concrete, large slabs etc.

Optional Items: Canopy, Base, Mats.

Product Code: MINI001.

Colour Options: Black, Red, Yellow, Royal Blue, Light Blue, Dark Green, Light Green, Grey, Stone effect, Multicolour.

MINIPOD ELEVATION

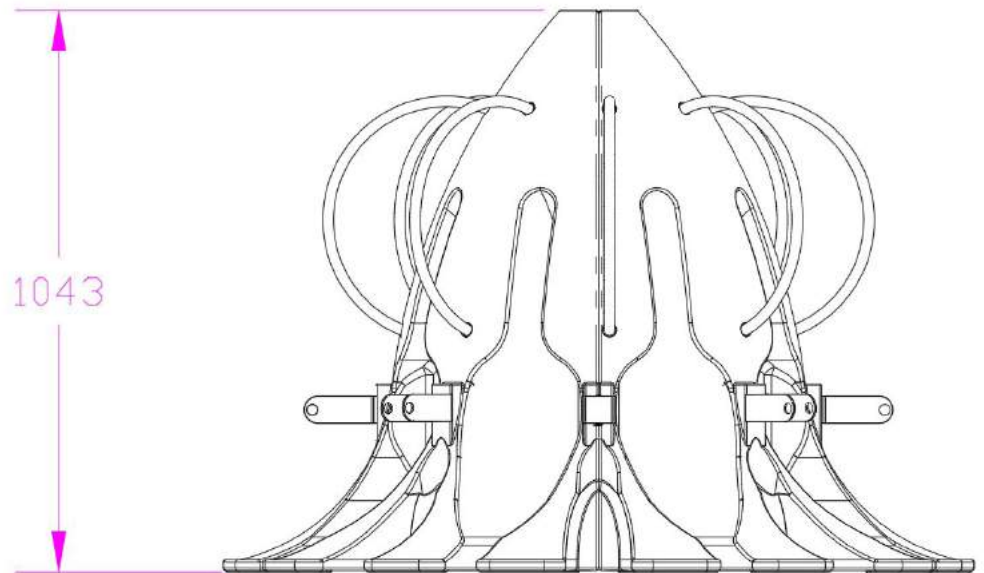

MINIPOD FIXING DETAIL

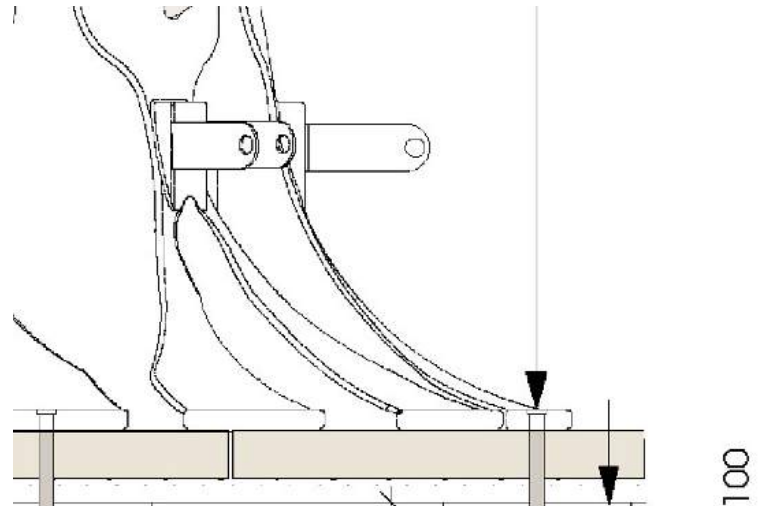

MINIPOD PLAN

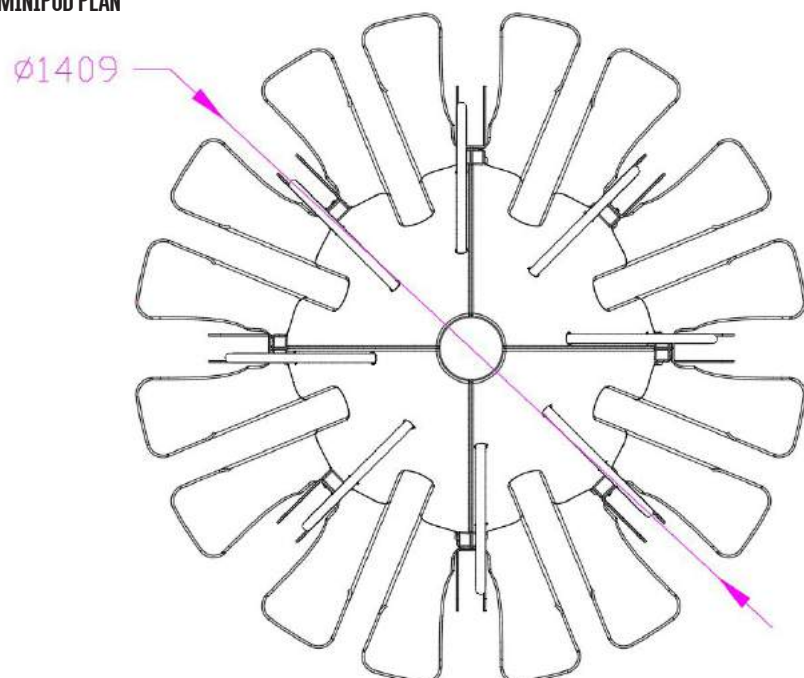

SCOOTERPOD

The Scooterpod is a unique and compact storage solution just for scooters! The fun and colourful innovation is ideal for nursery and primary schools, securing up to 12 scooters!

Like all Cyclepods' products, the Scooterpod is manufactured in the UK and available in 100% recycled materials. The Scooterpod; another space – saving, secure and eco-friendly design which doesn't require foundations!

Scooterpods are in over 4000 schools in the UK!

Combine it with the Linear Scooterpod to form Scooterpod Islands!



Product Name: Scooterpod

Material: 100% Recyclable MDPE plastic (colours, Red, Blue, Yellow, Green). 100% Recyclable and 100% Recycled MDPE plastic (black).

BREEAM: Our Scooterpods have been used successfully within BREEAM schemes throughout the UK.

Part Thickness: 14 mm.

Part Finish: Black, Blue, Yellow, Green, Red. Dimpled effect finish, gloss.

Part Weight: 6kg each. Overall weight 12Kg. Scooter Slots: Up to 12.

Fixing Method for Assembly: Nyloc nut and Washer.

Fixings Material: All standard Scooterpod fixings nickel plated.

Ground Fixings Required: 10mm outer diameter resin anchor bolts drilled to a depth of 100mm max. 3 fixing bolts required per half.

Ground Type Required: Various.

Optional Items: Canopy, Base, Mats
Product Code: SCO001.

Colour Options: Red, Yellow, Blue, Green, Black (recycled), Multicolour.

Various shelter options available for all products.

SCOOTERPOD 3D VIEW

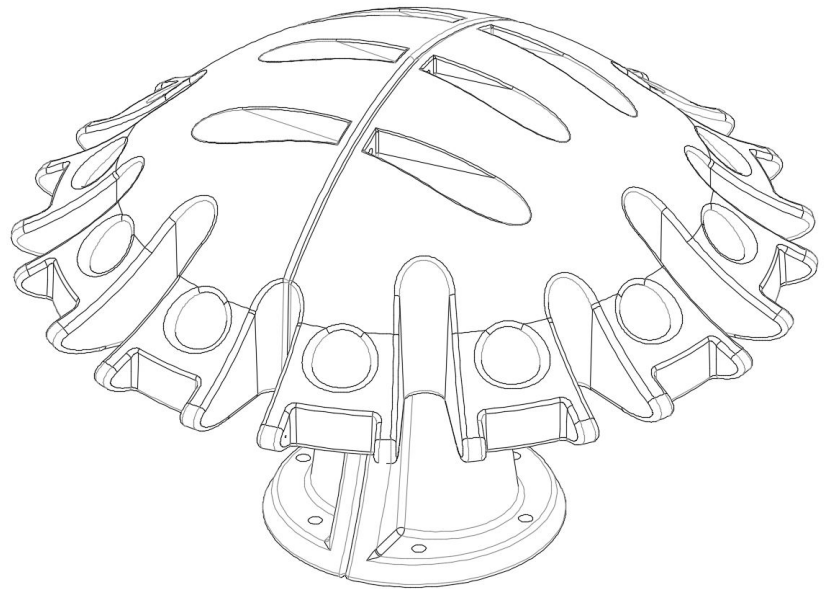

SCOOTERPOD SPACE REQUIREMENTS

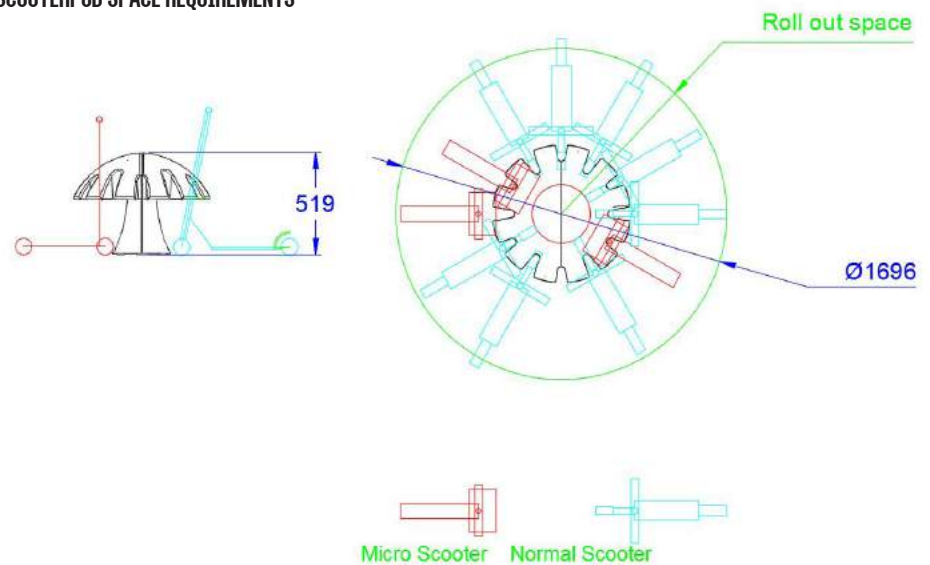

SCOOTERPOD WALL MOUNT OPTION

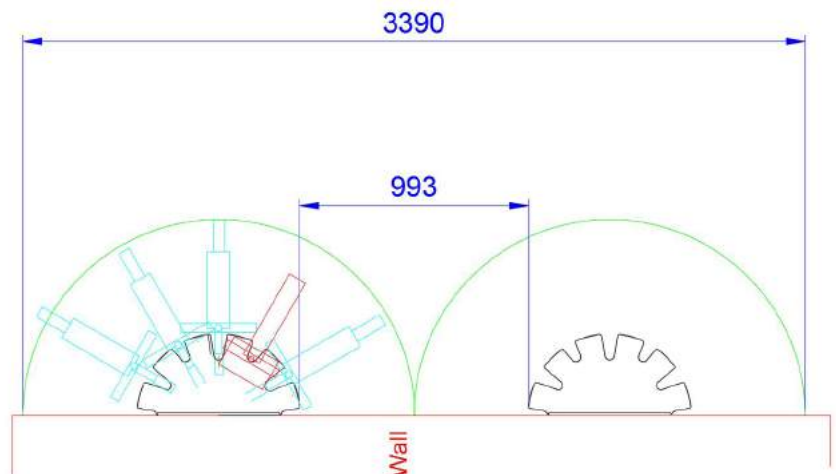

REPAIR XL MAINTENANCE STAND

The Repair XL maintenance stand is ideal for carrying out basic repairs such as repairing a puncture to adjusting brakes and gears. The tools are securely attached to the stand with PVC coated stainless steel cables and tamper-proof fasteners. Hanging the bike from the arms allows the pedals and wheels to spin freely whilst making adjustments. It is ideal for train stations, universities and even the high street!

Product dimensions:
D 530mm x H 1640mm.

Specification:

Main Body: 168mm x 5mm tube.

Bike Hanger: 48mm x 4mm tube.

Hand tools:

- Phillips and flat head screwdrivers.
- Allen key set.
- Torx T.25.
- Pedal Spanner.
- Adjustable spanner.
- 2x steel tyre levers.

Tool tethers: 3mm PVC coated stainless steel cable.

Hot dipped galvanised steel to BS EN ISO1461.

Galvanised finish as standard. Powder coating available as an option.

Installation Notes:

Bolt down fixing on to hardstanding.

Pump is NOT included. Please see our range of pumps.



PUMP XL BIKE PUMP

Help cyclists on their journey with the Cyclepods Pump XL bike pump. Featuring a waterproof pressure gauge, the Pump XL requires only minimal maintenance. Specifically designed for repeated heavy duty use, it is ideal for train stations, universities and even the high street!

It fits both Schrader and Presta valves, meaning that all cyclists are accommodated for.

Designed and made in the UK.

Product dimensions:
H 750mm x 140mm diameter.

Specification:
Main Body: 140mm x 5mm tube.
Top: 5mm Laser cut and etched Acrylic.
Foot: 5mm steel.
Hot dipped galvanised steel to BS EN ISO1461.
Oil-filled pressure gauge.
Steel reinforced rubber hose.
Security Fixings.

Galvanised finish as standard. Powder coating available as an option.
Colours available: Black, white, grey, red, orange, yellow, green, light green, light blue, brown, beige, purple.

5 year warranty on the steel casing,
12 month warranty on moving parts.
Please contact us for an extended warranty package.



KIT LOCKERS

Cyclists can need a lot of kit such as helmets, saddle bags, bike lights, extra clothes in case of weather changes, repair and maintenance kits etc. which they need to remove from their bike once it is stored in case of theft. Particularly if they are commuting, having to carry all these things with them all day as well as a change of clothes, laptops, handbags etc. isn't ideal. Kit lockers are an easy solution to this, they can keep their bike kits in the Hub safely all day whilst they continue their journey.



LOCK STANDS

Secure bike locks are heavy and cumbersome for cyclists to transport every day, especially difficult for commuters who already need to carry a lot on their journeys. Lock stands are for users to keep their locks in the cycle facility after they have retrieved their bike so they don't need to transport it back and forth. Dedicated lock stands prevent the bike storage stands from being cluttered or 'reserved' with locks.



MOTU CARGO PARK

The Motu is the ideal solution when it comes to safely parking cargo bikes, recumbent cycles, scooters and motorcycles. It allows users to securely lock their bicycle at the rear wheel, parked neatly within designated areas. The Motu is easily folded away when not in use, ensuring there is ample room for manoeuvring and that there are no obstacles on the road for pedestrians or local maintenance. The Motu will tilt upwards when you place your foot on the plastic and push backwards, allowing you to lock your bike. The Motu is installed flush with ground level, at the end of a parking space (see product plan). Its standard dimensions (30 x 30 cm) mean that the concrete base is very easy to install on the street.



CYCLE HUBS

Our Cycle Hubs are the cutting edge in high volume bike storage facilities. We provide a range of technology and equipment that can be used to create maximum security, access control, data recording and cyclist friendly amenities. Every hub has to be carefully designed to fit bespoke requirements and needs, so there is no such thing as a generic cycle hub. This is why we have created the ability to customise your hub by designing the individual components, so you can pick and choose exactly what goes into your hub!



ROOF STYLE

Several roof styles are available to customise your cycle hub, from no roof (ideal for Cycle Hubs built under a pre-existing structure) to gabled or arched. Pitch height can also be determined to fit your requirements.



ARCHED

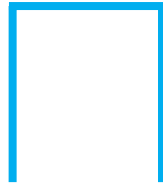

FLAT

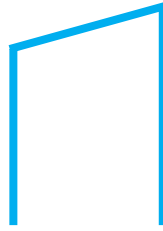

PITCHED



GABLE



NO ROOF

DESIGN

CLADDING STYLE

We provide cladding options to suit all environments. For conservation areas, a wood, composite or glass cladding is usually preferred. For public areas, perforated steel, glass or Kalzip are ideal as they allow for passive surveillance.



METAL SHEETING



GLASS



PET G



COMPOSITE



WOODEN PANELS

ROOF COVERING

As well as styles of roof, you can select your roof covering. PET G, chambered polycarbonate and metal roofing options are available as well as specialist green roofs.



GREEN ROOF

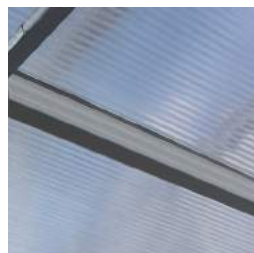

CHAMBERED
POLYCARBONATE



PET G



TRAPEZOIDAL
STEEL



Cyclepods can provide low-voltage electricity systems for your Cycle Hub to keep them as cost-effective, low-maintenance and sustainable as possible.

ACCESS CONTROL

If you are choosing to have a Cycle Hub with doors, Cyclepods offer several types of locks – from basic padlocks to full access control systems which work with many options such as key fobs, coded locks or key cards..

Our access technology systems are highly secure entry and exit controls which are easily adapted to suit any environment and location and can be easily retro-fitted to existing Hubs or linked to an existing ITSO-style travelcards such as The Key.



E-BIKE CHARGING UNITS

The trend in electric bike usage is increasing rapidly, so equipping your Cycle Hub with special points for electric bike parking is something to be considered.



CCTV

CCTV is an important security tool for any cycle parking facility. Having and advertising the presence of CCTV is also a great anti-theft deterrent.

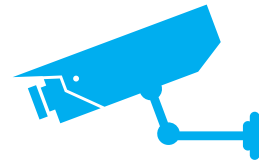

LIGHTING

Cyclepod's LED lighting systems ensure all areas of Cycle Hubs are well lit and inviting. These lights can be run off low-voltage electricity and triggered with PIR motion sensors to stay lit as long as movement within the hub is detected. This makes them energy-saving, long lasting and very low maintenance.



BIKE DETECTION

Bike Detection systems are a new concept to reach the UK but are already extremely popular in Cycle Hubs throughout Europe. Bike detection sensors can be installed into each space and linked to an LED screen at the hub entrance showing how many spaces are available. You can even go a step further and introduce an LED 'path' to guide users to the available spaces, saving them from having to search all over the hub for a space!

YOUR CYCLE HUB
300 TOTAL SPACES

2ND FLOOR: 45 SPACES FREE
1ST FLOOR: 8 SPACES FREE
GROUND FLOOR: FULL

SPACES AVAILABLE IN:
GROUND FLOOR: FULL
1ST FLOOR: ZONE 1 AND 2
2ND FLOOR: ZONE 1, 2, 4, 5 AND 6

HAVE A NICE DAY!

08:44

TESTIMONIALS

"The Streetpods seem to have been a great success, and much better used than the standard Sheffield racks that they replaced. D-locks are being left on them, which is a good indicator that they are being used regularly by the same people."

CHRIS ELLIOTT | LONDON CYCLING CAMPAIGN

"The Streetpods, with their innovative single locking feature and advertising panels seemed like the obvious choice to remedy the issue of fly-parking at the busy Peterborough Bus Station. As anticipated they were being used within an hour of them being installed."

MATTHEW BARBER | PETERBOROUGH COUNCIL

"The pods are used regularly by both male and female cyclists who always speak positively about their function. They also provide a great visual message about sustainable travel within our organisation and are regular talking point amount the local community."

FIONA DALY, ENVIRONMENTAL MANAGER | ST BART'S AND THE LONDON HOSPITAL

**CYCLEPODS LTD
2 BETSOMS BARN
PILGRIMS WAY
WESTERHAM
KENT
TN16 2DS**