

Challenger - Commercial



Built to withstand the toughest environment, Challenger cubicles are designed for high traffic and wet area use. Using solid grade laminate panels and carefully designed hardware system, these cubicles are the ultimate in durability for a long-lasting solution.

Challenger cubicles also have some great design features such as concealed fixings, 3 bolt-thru hinges per door and uses our exclusive range of high quality polished aluminium hardware for unrivalled durability in the washroom environment

designers and manufacturers of exemplary washroom systems

call 01603 424855 fax 01603 413336 email info@dunhamsofnorwich.co.uk
Dunhams Washroom Systems The Granary School Road Neatishead Norwich NR12 8BU

www.dunhamsofnorwich.co.uk

VAT Registration No. 105 2240 29

Partners BH Dunham MH Dunham JN Dunham SG Dunham TJ Percival

Specification

Pilasters/Divisions/Doors

Core/Face: Solid grade laminate with colour finish to both sides giving 13mm nominal thickness

Edge: Polished and radiused

Colour: From the Dunhams colour selector

Hardware

All fittings manufactured from high quality polished aluminium

Pedestals: Sturdy, solid rolled design with adjustable height to accommodate uneven floors

Hinges: High strength insert with anti-breakout sleeve and self-closing cams

Indicator Bolt Easy slide action lock with integrated buffer and emergency door release facility

Partition Fixing: Partitions secured with aluminium D brackets and stainless steel bolt-thru fixings

Headrail: D section headrail for maximum strength

Coat Hook: Matching coat hook, 1 per cubicle

Dimensions

Overall Height: 2000mm

Widths: from 700mm

Floor Clearance: 150mm

Depth: 1500mm standard (see quote for depth allowed)

Panel Thickness: 13mm

designers and manufacturers of exemplary washroom systems

call 01603 424855 fax 01603 413336 email info@dunhamsofnorwich.co.uk

Dunhams Washroom Systems The Granary School Road Neatishead Norwich NR12 8BU

www.dunhamsofnorwich.co.uk

VAT Registration No. 105 2240 29

Partners BH Dunham MH Dunham JN Dunham SG Dunham TJ Percival

Technical Drawings

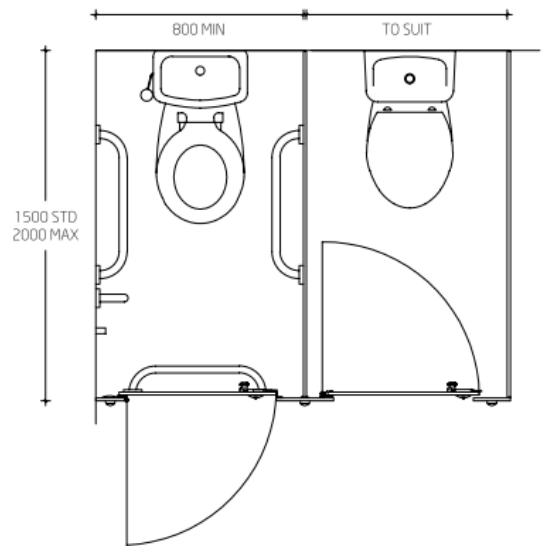
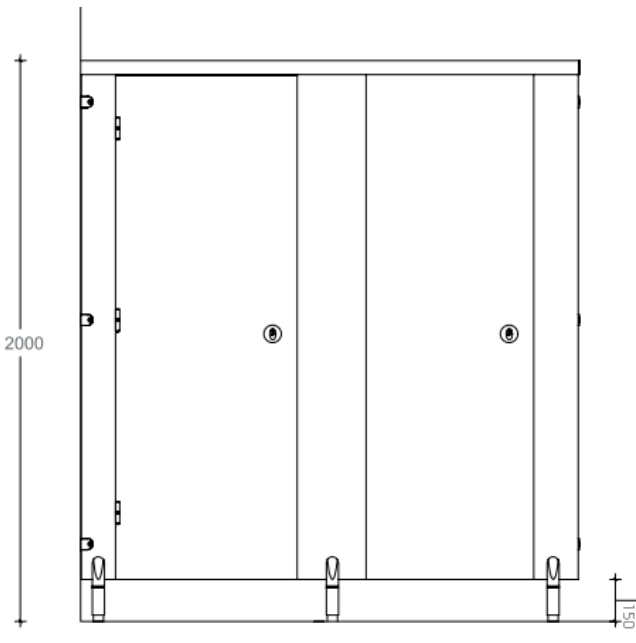
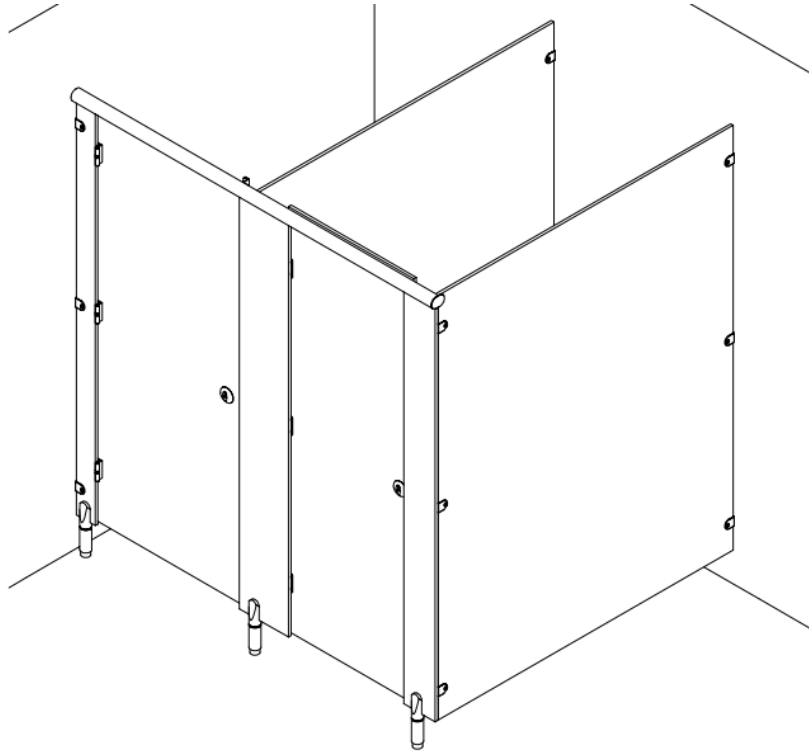

designers and manufacturers of exemplary washroom systems

call 01603 424855 fax 01603 413336 email info@dunhamsofnorwich.co.uk
Dunhams Washroom Systems The Granary School Road Neatishead Norwich NR12 8BU

www.dunhamsofnorwich.co.uk

VAT Registration No. 105 2240 29

Partners BH Dunham MH Dunham JN Dunham SG Dunham TJ Percival